



---

## **Li-Fi Based Under Water Communication**

*B. Srikanth<sup>1</sup>, C. Venkata Kumar<sup>2</sup>, P. Subahanulla Khan<sup>3</sup>, V. V. Hari Chandra Vara Prasad<sup>4</sup>*

*<sup>1,2,3,4</sup> Students, Department of Electronics and Communication, Santhiram Engineering College, India*

---

### **ABSTRACT**

Underwater Communication is used to keep track of obstacles and ocean species. Wi-Fi cannot be used in underwater communication because in water the Radio Waves are get absorbed. Li-Fi can be used underwater because light can penetrate deep water. There are number of communications mediums available in wired and wireless sector. Especially wireless communication brings lot of convenience to our lives. All cell phone and other wireless gadgets working through wireless communication. RF, Zigbee, Bluetooth and Zigbee are wireless communication protocols and can perform their respective functionalities in hardware. Traditional radio waves will not penetrate through water. But light can penetrate and travel through water. LIFI technology works on light communication and can travel through water. This project name is LIFI based underwater communication using Arduino.

Keywords: Power Supply, Arduino Uno , Li-Fi Module, LED Array , PC

---

### **1. INTRODUCTIONS**

LiFi (light fidelity) is a bidirectional wireless system that transmits data via LED or infrared light. It was first unveiled in 2011 and, unlike wifi, which uses radio frequency, LiFi technology only needs a light source with a chip to transmit an internet signal through light waves. This is an extraordinary advance over today's wireless networks. LiFi multiplies the speed and bandwidth of wifi, 3G and 4G. The latter have a limited capacity and become saturated when the number of users surfing increases, causing them to crash, reducing speeds and even interrupting the connection. With LiFi, however, its band frequency of 200,000 GHz, versus the maximum 5 GHz of the wifi, is 100 times faster and can transmit much more information per second. A 2017 study by the University of Eindhoven obtained a download rate of 42.8 Gbit/s with infrared light with a radius of 2.5 metres, when the best wifi would barely reach 300 Mbit/s. Airports, hospitals and city streets are other spaces where LiFi technology could become popular. The boom in mobile devices and the growing demand for higher bandwidth systems are expected to drive the development of this social technology in the next decade, as noted in the Global Market for LiFi Technology Analysis and Forecast 2018-2028.

---

### **2. PROPOSED SYSTEM**

#### **TRANSMITTER:**

The methodology of this transmitter is as follows:

The Arduino Uno generates a digital signal, which is then converted to an electrical signal by the Li-Fi module. The Li-Fi module then modulates the electrical signal with the LED array. The modulated electrical signal is then transmitted to the receiver through the air using light.

#### **RECEIVER:**

The methodology of this receiver is as follows:

The Li-Fi module receives the modulated optical signal from the transmitter. The Li-Fi module then demodulates the optical signal and converts it back to an electrical signal. The electrical signal is then processed by the Arduino Uno.

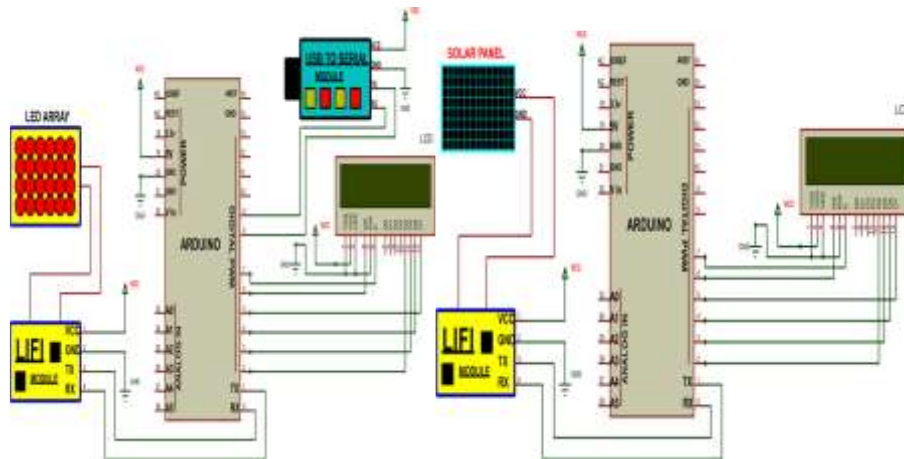

### 3. WORKING PRINCIPLE

In this project we are transmitting text data from LIFI transmitter to LIFI receiver. LIFI transmitter section contains PC, Arduino and LIFI transmitter. From serial terminal we have to give data and data will transmit to Arduino. Then Arduino transmits same data to LIFI module and converts into light. LIFI receiver section receives data through its solar panel and data will be displayed on 16x2 LCD display. For Demonstration purpose we can use glass tub with water for LIFI communication. Need to keep glass water tub between LIFI transmitter and LIFI receiver.

Arduino and LIFI module are connected together through UART port. LIFI module transmits and receives data through UART port and data level in RS232. At LIFI transmitter side Arduino connected to PC through another serial port.

### 4. ARDUINO UNO

The ARDUINO Uno is an open-source microcontroller based on the Microchip ATmega328P microcontroller and developed by Arduino.cc. The board is equipped with sets of digital and analog input/output (I/O) pins that may be interfaced to various expansion boards (shields) and other circuits. The board has 14 digital I/O pins (six capable of PWM output), 6 analog I/O pins, and is programmable with the ARDUINO IDE(Integrated Development Environment), via a type B USB Cable. It can be powered by the USB cable or by an external 9-volt battery, though it accepts voltages between 7 and 20 volts. It is similar to the ARDUINO NANO and Leonardo. The hardware reference design is distributed under a Creative Commons Attribution Share-Alike 2.5 license and is available on the ARDUINO website.



### 5.SOFTWARE TOOL DESCRIPTION

The Arduino Software (IDE) makes it easy to write code and upload it to the board offline. We recommend it for users with poor or no internet connection. This software can be used with any Arduino board here are currently two versions of the Arduino IDE, one is the IDE 2.0.0. Here are currently two versions of the Arduino IDE, one is the IDE 1.x.x and the other is IDE 2.x. The IDE 2.x is new major release that is faster and even more powerful to the IDE 1.x.x. In addition to a more modern editor and a more responsive interface it includes advanced features to help users with their coding and debugging

## 6. RESULTS

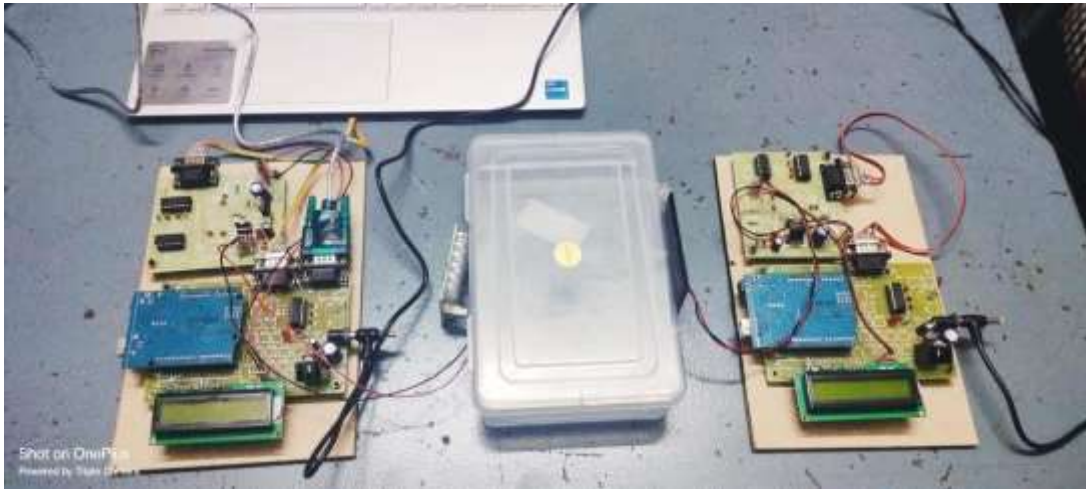
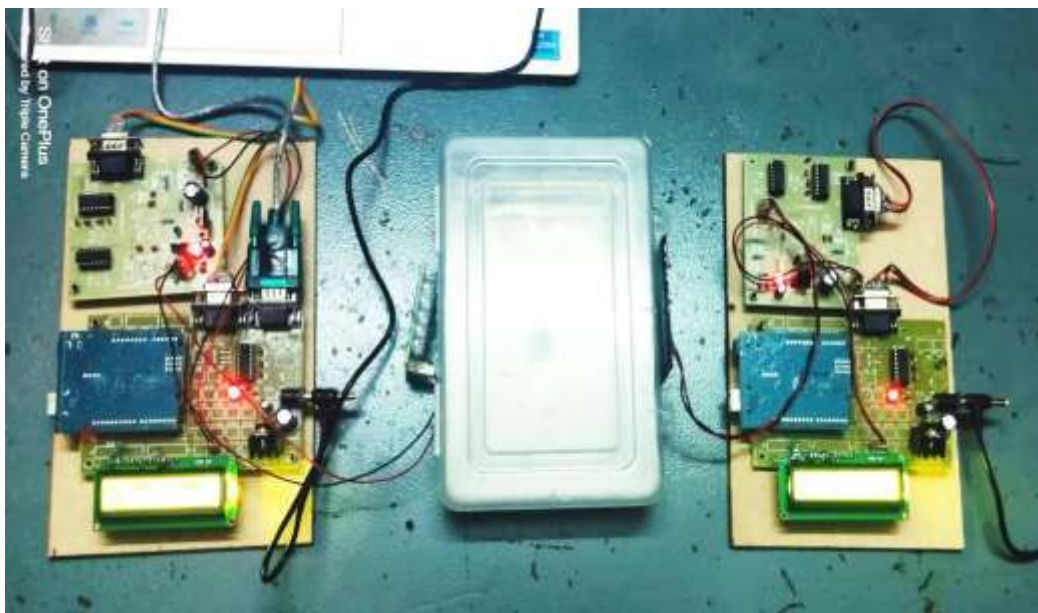

Fig shows the overall working model of the Li-Fi based underwater communication. Here in above model all the pieces are connected without giving power supply. The working of the above model can be shown below.



## 7. CONCLUSION AND FUTURESCOPE

Li-Fi based underwater communication is a promising technology that offers several advantages over traditional underwater communication methods. It is capable of transmitting high-speed data securely and without causing interference to marine life, making it a suitable choice for a wide range of underwater applications. As Li-Fi technology continues to develop and mature, it is expected to play an increasingly important role in underwater communication, enabling new applications and expanding our understanding of the underwater world. Overall, Li-Fi based underwater communication is a promising and rapidly developing technology that has the potential to transform underwater communication and exploration. With its unique advantages and wide range of potential applications, Li-Fi is poised to become a key enabler for the next generation of underwater technologies.

The future of Li-Fi-based underwater communication is bright and full of possibilities. This emerging technology has the potential to revolutionize underwater communication, exploration, and research. With its high bandwidth, low latency, and security features, Li-Fi will enable a wide range of applications, including ubiquitous underwater connectivity, enhanced underwater exploration, environmental monitoring and protection, underwater infrastructure monitoring and maintenance, secure underwater communication for military and defense, underwater aquaculture and marine research, underwater maritime communication and navigation, oceanographic research and exploration, underwater disaster management and rescue operations,

and underwater education and outreach. As Li-Fi technology continues to develop, we can expect to see even more innovative and transformative applications that will expand our understanding of the underwater world and make it a more accessible and interconnected space.

---

**References**

---

- Mei Yu Soh, Wen Xian Ng, Qiong Zou, Denise Lee, T. Hui Teo, and Kiat Seng Yeo, “Real-Time Audio Transmission Using Visible Light Communication”, 2018.
- Ashish Kumar Das, Arpita Ghosh, A. M. Vibin and Shanthi Prince, “Underwater Communication System for Deep Sea Divers Using Visible Light”, 2012.
- Anurag Sarkar, Salabh Agarwal, Ashoke Nath, “Li-Fi Technology: Data Transmission through Visible Light”, 2015.
- C. Periasamy, K. Vimal, D. Surender, “LED Lamp Based Visible Light Communication in Underwater Vehicles”, 2014.
- R. Karthika, S. Balakrishnan, “Wireless Communication using Li-Fi Technology”, 2015
- Priyanka Tupe Waghmare, Parul Garg, “Voice Activated Li-Fi Operated Surveillance System”, 2015.
- Robert Codd-Downey and Michael Jenkin. “Wireless Teleoperation of an Underwater Robot using Li-Fi”, 2018.
- Evangelos Pikasis and Wasiu O. Popoola, “Understanding LiFi Effect on LED Light Quality”, 2018.