



## **A Survey of Indoor Travel Assistance Systems for Blind and Visually Impaired People Using Li-Fi And Zigbee**

<sup>1</sup>*Mr. G. Saravanan, M.E.,* <sup>2</sup>*Ms. B. Swathi, B.E.*

<sup>1</sup>Assistant professor, Department of Electronics and Communication Engineering, Apollo Engineering College

<sup>2</sup>Department of ME VLSI DESIGN, Engineering Students of Apollo Engineering College

### **ABSTRACT-**

I proposed an indoor navigation system that utilizes visible light communication technology, which employs LED lights and a geomagnetic correction method, aimed at supporting visually impaired people who travel indoors. To verify the effectiveness of this system, I conducted an experiment targeting visually impaired people. Although acquiring accurate positional information and detecting directions indoors is difficult. I have confirmed that using this system, accurate positional information and travel direction can be obtained utilizing visible light communication technology, which employs LED lights, and correcting the values of the sensors integrated in system.

### **INTRODUCTION**

In this system, I have Arduino UNO microcontroller which acts as brain of our system, hence, the entire system program is stored in it.

Here, every room enabled with Light transmitter that transmits unique data, while, blind people has one unit that consists of receiver unit that consists microcontroller along with APR module that plays preloaded voice messages. Owing to power limitations and hardware constraints of the Internet of Things (IOT) device, it requires simple, low power, low complex, energy-efficient communication technology. In contrast, Li-Fi users require high data rates and reliable connectivity. Motivated by the diverse requirements of these heterogeneous users, this paper proposes novel green communication schemes that can be used for the coexistence of Li-Fi users and light communication (LC) enabled IOT devices under a common Li-Fi access point.

#### **LI-FI:**

Li-Fi (also written as Li-Fi) is a wireless communication technology which utilizes light to transmit data and position between devices. The term was first introduced by Harald Haas during a 2011 TED Global talk in Edinburgh. Li-Fi is a light communication system that is capable of transmitting data at high speeds over the visible light, ultraviolet, and infrared spectrums. In its present state, only LED lamps can be used for the transmission of data in visible light. In terms of its end user, the technology is similar to Wi-Fi — the key technical difference being that Wi-Fi uses radio frequency to induce a voltage in an antenna to transmit data, whereas Li-Fi uses the modulation of light intensity to transmit data. Li-Fi is able to function in areas otherwise susceptible to electromagnetic interference (e.g. aircraft cabins, hospitals, or the military).

Bg-Fi is a Li-Fi system consisting of an application for a mobile device, and a simple consumer product, like an IOT (Internet of Things) device, with color sensor, microcontroller, and embedded software. Light from the mobile device display communicates to the color sensor on the consumer product, which converts the light into digital information. Light-emitting diodes enable the consumer product to communicate synchronously with the mobile device.

#### **ZIGBEE:**

ZIGBEE is a standards-based wireless technology developed to enable low-cost, low-power wireless machine-to-machine (M2M) and internet of things (IOT) networks. ZIGBEE is for low-data rate, low-power applications and is an open standard. The technology defined by the Zigbee specification is intended to be simpler and less expensive than other [wireless personal area networks](#) (WPANs), such as [Bluetooth](#) or more general wireless networking such as [Wi-Fi](#). Applications include wireless light switches, [home energy monitors](#), traffic management systems, and other consumer and industrial equipment that requires short-range low-rate wireless data transfer.

Its low power consumption limits transmission distances to 10–100 meters [line-of-sight](#), depending on power output and environmental characteristics. Zigbee devices can transmit data over long distances by passing data through a [mesh network](#) of intermediate devices to reach more distant ones. Zigbee

is typically used in low data rate applications that require long battery life and secure networking. (Zigbee networks are secured by 128 bit [symmetric encryption](#) keys.) ZIGBEE has a defined rate of up to 250 kbit/s, best suited for intermittent data transmissions from a sensor or input device.

### ULTRASONIC SENSOR:

The transmitter that can emit up to 8 bursts of a directional 40 KHz ultrasonic wave when it is triggered and then starts the timer. Thus the ultrasonic pulses travel outward until they encounter an object. The object that causes the wave that should be reflected back towards the unit. The ultrasonic receiver would detect the reflected wave and stop the timer. 340m/sec is the velocity of the ultrasonic burst in air. Based on the number of counts by the timer, the distance can be calculated between the object and transmitter. The TRD Measurement formula is expressed as:  $D = C \times T$  which is known as the time/rate/distance measurement formula, where D is the measured distance, and R is the propagation velocity.

Digital image processing has a broad spectrum of applications, such as remote sensing via satellites and other spacecraft's, image transmission and storage for business applications, medical processing, radar, sonar and acoustic image processing, robotics and automated inspection of industrial parts. expressed in (Rate) in air (speed of sound) and T which represents time. In this application T is divided by 2 as T is double the time value from transmitter to object back to receiver. The features of the ultrasonic sensor are, it has the close range of 2 centimetres. Then it should have the stable performance. Ultrasonic sensors measure the accurate distance between the obstacle and other disturbances. These sensors have the high density SMD board.

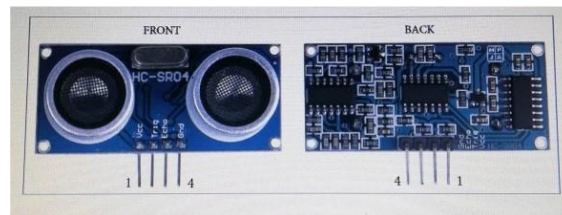

Fig3. Image of Ultrasonic sensor

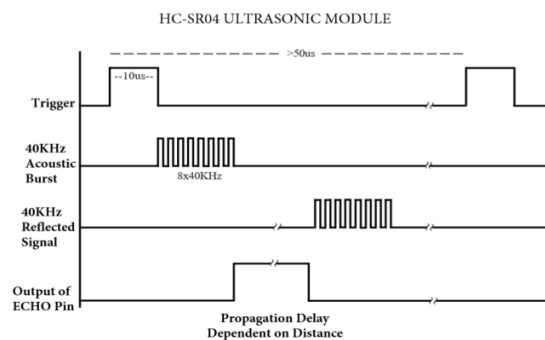

Fig 4. Graph of a ultrasonic module

### ARDUINO UNO:

The Arduino Uno is an open-source microcontroller board based on the Microchip ATmega328P microcontroller and developed by Arduino.cc and initially released in 2010. The board is equipped with sets of digital and analog input/output (I/O) pins that may be interfaced to various expansion boards (shields) and other circuits. The board has 14 digital I/O pins (six capable of PWM output), 6 analog I/O pins, and is programmable with the Arduino IDE (Integrated Development Environment), via a type B USB cable. It can be powered by a USB cable or a barrel connector that accepts voltages between 7 and 20 volts, such as a rectangular 9-volt battery. It is similar to the Arduino Nano and Leonardo. The hardware reference design is distributed under a Creative Commons Attribution Share-Alike 2.5 license and is available on the Arduino website. Layout and production files for some versions of the hardware are also available.

The word "uno" means "one" in Italian and was chosen to mark a major redesign of the Arduino hardware and software. The Uno board was the successor of the release and was the 9th version in a series of USB-based Arduino boards. Version 1.0 of the Arduino IDE for the Arduino Uno board has now evolved to newer releases. The ATmega328 on the board comes preprogrammed with a bootloader that allows uploading new code to it without the use of an external hardware programmer.

While the Uno communicates using the original STK500 protocol, it differs from all preceding boards in that it does not use a FTDI USB-to-UART serial chip. Instead, it uses the Atmega16U2 (Atmega8U2 up to version R2) programmed as a USB-to-serial converter.



### ***LI-FI TRANSMITTER:***

The Li-Fi Transmitter is a custom-design front-end for visible light communications (VLC). It has a wide bandwidth (25 MHz) to support even the most demanding video streaming applications. The transmitter has a powerful 5000K 186 lumen LED with an interchangeable lens mechanism. Li-Fi technology uses led for transmitting data. It is derivative of optical wireless communication technology using light from Led to deliver high speed communication. Visible light communication works by switching the Led off and on at very high speed, it can't noticed by the human eye.

### ***LI-FI RECEIVER:***

Li-Fi Receiver is a custom-design front-end for visible light communications (VLC). It has a wide bandwidth (20 MHz) to support even the most demanding video streaming applications. The receiver features a photo detector with a field-of-view of 170° enabling a robust performance in non line-of-sight conditions.

### ***ARDUINO SOFTWARE IDE:***

The Arduino Integrated Development Environment - or Arduino Software (IDE) - contains a text editor for writing code, a message area, a text console, a toolbar with buttons for common functions and a series of menus. It connects to the Arduino and Genuino hardware to upload programs and communicate with them.



---

### **EMBEDDED C:**

Embedded C is most popular programming language in software field for developing electronic gadgets. Each processor used in electronic system is associated with embedded software.

Embedded C programming plays a key role in performing specific function by the processor. In day-to-day life we used many electronic devices such as mobile phone, washing machine, digital camera, etc. These all device working is based on microcontroller that are programmed by embedded C.

Let's see the block diagram representation of embedded system programming:

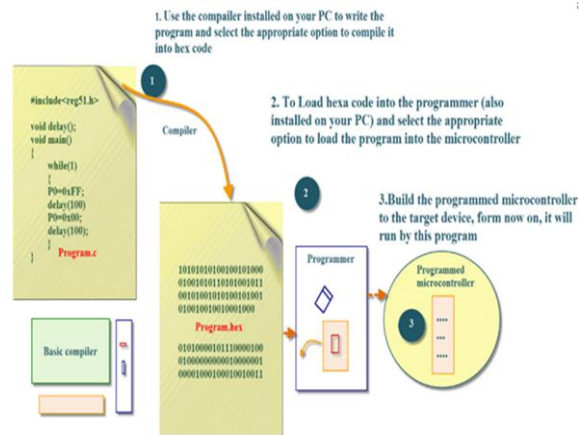

The Embedded C code written in above block diagram is used for blinking the LED connected with Port0 of microcontroller.

In embedded system programming C code is preferred over other language. Due to the following reasons:

- Easy to understand
- High Reliability
- Portability
- Scalability

## EMBEDDED SYSTEM PROGRAMMING:

Basic Declaration

Let's see the block diagram of Embedded C Programming development:

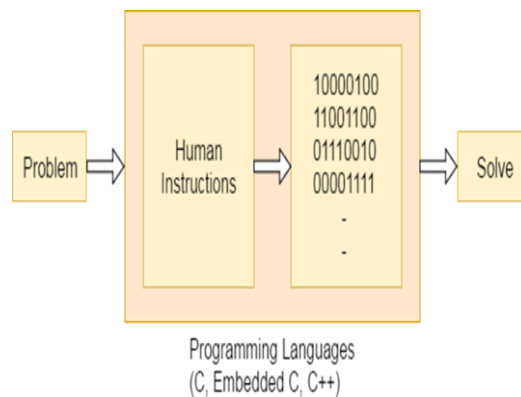

Function is a collection of statements that is used for performing a specific task and a collection of one or more functions is called a programming language. Every language is consisting of basic elements and grammatical rules. The C language programming is designed for function with variables, character set, data types, keywords, expression and so on are used for writing a C program.

The extension in C language is known as embedded C programming language. As compared to above the embedded programming in C is also have some additional features like data types, keywords and header file etc is represented by `#include<microcontroller name.h>`.

## HARDWARE SPECIFICATIONS

POWER SUPPLY

ARDUINO UNO

LCD

IR SENSOR  
 ULTRASONIC SENSOR  
 APR VOICE MODULE  
 SPEAKER  
 RELAY  
 DC FAN  
 LI-FI TX&RX

**SOFTWARE SPECIFICATIONS**

ARDUINO IDE  
 EMBEDDED C LANGUAGE

**BLOCK DIAGRAM:**

**TRANSMITTER SECTION:**

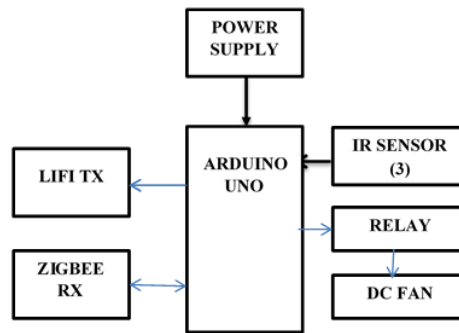

Fig : Transmitter section Block Diagram

**RECEIVER SECTION:**

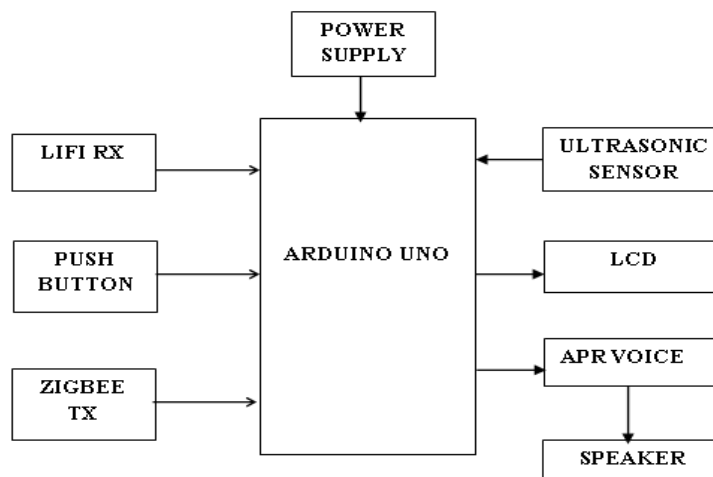

Fig : Receiver section Block Diagram

**SYSTEM DESIGN:**

The proposed system which overcomes the existing system is given as,

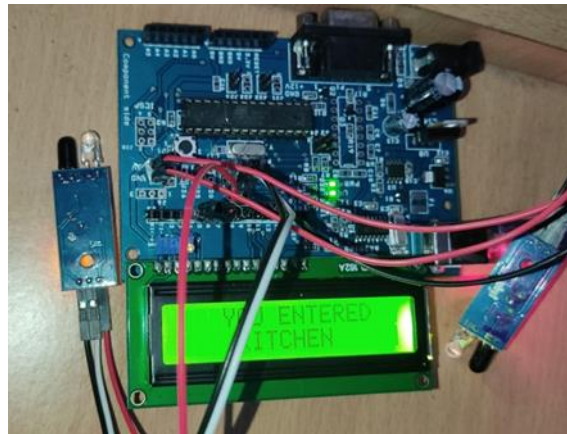

Fig . The hardware configuration of proposed li-fi device

---

## CONCLUSION:

For the first time, this paper explores the coexistence of Li-Fi and zigbee users and LC enabled IOT devices under a common Li-Fi AP for green DL and UL communication. The proposed coexistence schemes one for DL and another for UL communication utilize the amalgamation of WDM, OFDMA, DCO-OFDMH, NDCE, DHT precoding, interleaved subcarrier mapping and MDS to achieve concurrent interference-free, low complex and reliable communication. The proposed and conventional DCO-OFDMH based coexistence schemes have been extensively analyzed with respect to seven performance metrics as iterated in order of preference, viz. system complexity, PAPR, ESE, the maximum number of IOT devices (Km), power saving with respect to QAM-DCO-OFDMH, EH, and SNR. The results suggest that \*PAMUp-MDS-P-DCO-OFDMH provides the least computational complexity (against rest schemes analyzed in this work) of  $O(1)$  and  $O(Q)$  at the LC enabled IOT and Li-Fi user's terminal, therefore is most suitable for DL scenarios with massive IOT devices and few Li-Fi users. The derived analytical results are in good agreement with the simulated results.

## REFERENCES

1. Special Cane with Visual Odometry for Real-time Indoor Navigation of Blind People Jingyu Tang<sup>1</sup>, Menghan Hu<sup>1,2\*</sup>, Guodong Li<sup>1</sup>, Qingli Li<sup>1</sup>, East China Normal University, China <sup>2</sup>Key Laboratory of Artificial Intelligence, Ministry of Education, China Corresponding author: Menghan Hu (mhhu@ce.ecnu.edu.cn)
2. Seamless Pedestrian Navigation Methodology Optimized for Indoor/Outdoor Detection Qinghua Zeng, Jingxian Wang, Qian Meng, Xiaoxue Zhang, and Shijie Zeng
3. Smartphone Based Indoor Navigation for Blind Persons using User Profile and Simplified Building Information Model Summan Zaib Department of Computer Science University of Peshawar Peshawar, Pakistan summonzeb@gmail.com Shah
4. Low Cost Smart Navigation System for the Blind barathi Kanna S, Ganesh Kumar T R, Niranjana C, Prashanth S, Rolant Gini J, M.E. Harikumar Department of Electronics and Communication Engineering Amrita School of Engineering, Coimbatore Amrita Vishwa Vidyapeetham, India
5. Wearable Navigation Device for Virtual Blind Guidance K. Dhivya<sup>1</sup> Assistant Professor/ECE IFET College of Engineering Villupuram, India k.dhivya91@gmail.com