



Solar Inverter with Auto Overload Protection

Shivkumar Pandoliya¹, Prajwal Khanke², Prof Diksha Chiwande³

¹Student (ECE) SSCET

²Student (ECE) SSCET

³Asst. Professor (ECE) SSCET, Bhadrwati

ABSTRACT:

We live in a wired world, where nearly everything in our lives requires a steady supply of electricity to remain in operation. Sometimes extreme weather conditions, car accidents, falling trees, unusually high power demands, or even damage caused by animals can cause severe disruptions in a local or regional electrical grid, leaving our home without electricity for hours or more at a time. So, we use inverter in our houses. Inverters are widely used in the domestic as well as industrial environments to serve as a second line of source. A solar inverter's main job is to convert DC power generated from the photovoltaic cell into AC power. Hybrid inverters go a step further and work with batteries to store excess power as well. But this solar inverter system is inefficient in charging the battery during cloudy weather condition.[1]

Introduction :

Solar energy systems have emerged as a viable source of renewable energy over the past two or three decades, and are now widely used for a variety of industrial and domestic applications. Such systems are based on a solar collector, designed to collect the sun's energy and to convert it into either electrical power or thermal energy [3] Solar inverter is a critical component in a solar energy system. It converts DC power output into AC current that can be fed into the grid and directly influences the efficiency and reliability of a solar energy system. On most occasions, 220VAC and 110VAC need for power supply. Because the direct output of solar energy is usually 12VDC, 24VDC, or 48VDC, it is necessary to use DC-AC inverter in order to be able to supply power to 220VAC electronic devices. Inverters are generally rated by the amount of AC power they can supply continuously. In general, manufacturers provide 5 second and 1/2 hour surge figures which give an indication of how much power is supplied by the inverter. Solar inverters require a high efficiency rating. For use of solar cells remains relatively costly, it is paramount to adopt high efficiency inverter to optimize the performance of solar energy system. High reliability helps keep maintenance cost low. Since most solar power stations are built in rural areas without any monitoring manpower, it requires that inverters have competent circuit structure, strict selection of components and protective functions such as internal short circuit protection, overheating protection and overcharge protection. Wider tolerance to DC input current plays an important role since the terminal voltage varies depending on the load and sunlight. Though energy storage batteries are significant in providing consistent power supply, variation in voltage increases as the battery's remaining capacity and internal resistance condition changes, especially when the battery is ageing, widening its terminal voltage variation range. In mid-to-large capacity solar energy systems, inverters, power output should be in the form of sine waves which attain less distortion in energy transmission. Many solar energy power stations are equipped with gadgets that require higher quality of the electricity grid, which, when connected to the solar systems, requires sine waves to avoid electric harmonic pollution from the public power supply network.[4]

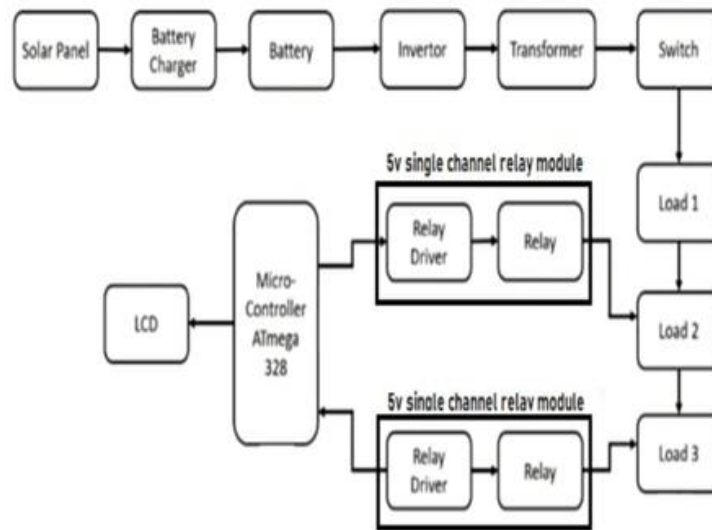
Diagram:**Major Components:****Arduino**

The Arduino Uno is a microcontroller board based on the ATmega328. It has 14 digital input/output pins (of which 6 can be used as PWM outputs), 6 analog inputs, a 16 MHz ceramic resonator, a USB connection, a power jack, an ICSP header, and a reset button. Arduino board designs use a variety of microprocessors and controllers. The boards are equipped with sets of digital and analog input/output (I/O) pins that may be interfaced to various expansion boards or breadboards (shields) and other circuits. The boards feature serial communications interfaces, including Universal Serial Bus (USB) on some models, which are also used for loading programs from personal computers. The microcontrollers are typically programmed using a dialect of features from the programming languages C and C++. In addition to using traditional compiler tool chains the Arduino project provides an integrated development environment (IDE) based on the Processing language project.

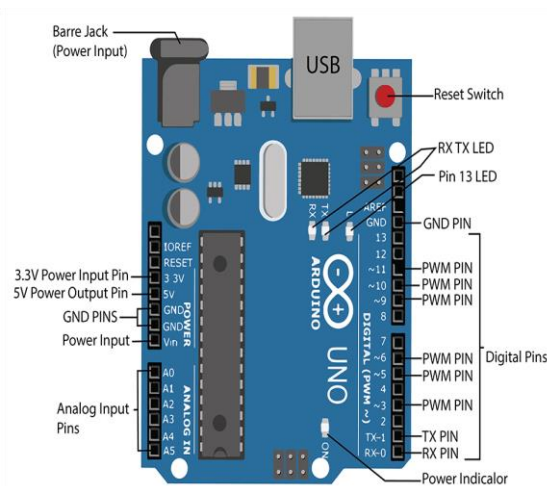
**Solar panel**

Solar panel refers to a panel designed to absorb the sun's rays as a source of energy for generating electricity or heating. A photovoltaic (in short PV) module is a packaged, connected assembly of typically 6×10 solar cells. Solar Photovoltaic panels constitute the solar array of a photovoltaic system that generates and supplies solar electricity in commercial and residential applications. Each module is rated by its DC output power under standard test conditions, and typically ranges from 100 to 365 watts[5]



Working:

Solar panels capture sunlight as a source of radiant energy, which is converted into electric energy in the form of direct current (DC) electricity. When sunlight falls on the solar panel then EMF is generated and a current starts to flow that will eventually charges the battery. Then power is stored in the battery via battery charger. The battery charge is connected between solar panel and battery. The use of battery charger is to protect the battery from extra supply. Then battery will give DC source to the inverter and then inverter will convert DC source (12v) into AC source (12). Inverter will give AC source to step up transformer and then it will convert low voltage supply (12v) into high voltage supply (230v). After that the transformer will transfer the supply to the switch. Switch is used for ON and OFF purpose, so it controls the load by using ON -OFF buttons.

Condition 1: If switch1 is ON state, then condition is normal, so LED Bulb blows.

Condition 2: If switch 1 and switch 2 are ON state, then the relay will sense the load and relay will send the signal to micro-controller that Load1 and Load2 are connected means condition is intermediate. After LCD shows that "Load is Detect".

Condition 3: If switch 1, switch 2 and switch3 are ON state, then the LED2 AND LED3 are automatically disconnected and only LED1 will work because we are using the LED1 as a emergency lamp. the relay module will sense that high load connected, then it will automatically disconnect due to over load and it will send signal to microcontroller and micro-controller will send signal to LCD display and LCD shows that "No Load". The overall result if apply load1 then condition is normal. Then if we apply Load1, Load2 then the display will show the load is connected. After that if switch1, switch2 and switch3 are ON, then the LED2 and LED3 automatically OFF, only LED1 will blow, then the relay will operate and it will send the signal to micro-controller that the all loads are connected and due to overload the circuit will automatically disconnected. Hence our appliances are protected from high load.

Advantages:

- More efficient transmission and distribution of electricity
- Quicker restoration of electricity after power outages.
- Increased and efficient integration of variable energy system.
- Inexpensive and easy to design
- Inbuilt battery charging circuit to charge using mains.

Applications:

1. Outdoor street lightning
2. Lightning of commercial buildings. Rural and village lightning's.
3. Transmissions and communication towers and many more application are: i. Monitoring system ii. Irrigation iii. Telecommunication system and etc.[8]

Conclusion:

Sun, being source of clean, pollution-free energy, we can have many devices powered by solar energy most of the times. Recent technological developments in thin-film photo voltaic (pvs), such as amorphous silicon and hybrid dye sensitized/PV cells are leading to new generations of consumer portable solar arrays. These new arrays are lightweight, durable, flexible, and have been reported to achieve power efficiencies of up to 10%. Yet are able to produce up to 50W of power at 12Volts.[10] Thus we design a solar inverter diagram and hardware is developed, hence we observe the result. It is also a preferred power backup to a computer and other appliances because it switches automatically to the battery when the AC mains is not available.

Future Scope:

As whole world is facing a problem of global warming and energy crisis, our project will help to reduce these problems by using solar energy to generate electricity. Solar energy is an infinite source of energy. Main motto of our project is to promote use of renewable energy sources. This project is most useful in our life because in this project one time investment fixed on life time. In future one day nonrenewable energy will end then we will use to the renewable energy. The solar inverter made by us is just a prototype for making future projects which incorporate advanced technologies like micro controlled solar tracking, charge control, etc. This is to show that solar inverters are very cheap and easy to install so that the energy demands are shifted on using renewable sources of energy.

References

- [1] Swakhar Shome, Souhardya Chakravorty, Subhajit Pal, "Hybrid Inverter With Solar Battery Charger"
- [2] Rashmi Prof. Ganesh Manasali Shradha, "Solar Based Inverter Using Microcontroller" 2022 Ijcert | Volume 10, Issue 7 July 2022 | Issn: 2320-2882
- [3] Prajakta S. Kasulakar Chetan B. Deth. "Single Phase Inverter Using Pwm Technique" International Journal Of Engineering Applied Sciences And Technology, 2020 Vol. 4, Issue 10, Issn No. 2455-2143
- [4] G. Nagaraju, A. Satish Kumar, K. Naresh, T. Amar Kiran, "Hybrid Power Generation System With Inverter Using Android Based Load Control"
- [5] B. Ravi Teja, Dr. G. Jayakrishna, Akhib Khan Bahamani, "Hybrid Inverter With Solar Battery Charging" **Journal Of Emerging Technologies And Innovative Research**
- [6] Srashti Layyar, Tushar Saini, Abhishek Verma, Ashwani Kumar, "Hybrid Inverter With Wind And Solar Battery Charging", Journal Article // [International Journal Of Engineering And Technical Research](#) July 2018
- [7] Mrunali Patole, Deepali Palange, Aishwarya Gavali, Sphoorti Shivarai, "Hybrid Inverter With Solar Battery Charging System", International Journal Of Research Publication And Reviews Journal Homepage: [Www.Ijrpr.Com](#) Issn 2582-7421
- [8] Shamik Chattaraj, Rajeev Kumar, Sajal Maity, "Hybrid Inverter Using Solar CHARGER" International Journal Of Recent Research In Electrical And Electronics Engineering (JRREEE) Vol. 5, Issue 2
- [9] | Nidhi Patil, Neha Sase, Kunal Chaudhari, Prof. Rehab Upletawala, "Dual Axis Solar Tracking Using LDR With Inverter" International Research Journal Of Engineering And Technology (IRJET) E-ISSN: 2395-0056 Volume: 08 Issue: 05
- [10] Prof. Swapnil Namekar, Fardeen Khan, "Hybrid Inverter With Solar Battery Charger" IJCRT | Volume 10, Issue 11 November 2022 | ISSN: 2320-2882