



Arduino Assisted Vending Machine with RFID Technology

Gopal Gawande ^[A], Atharv Aher ^[B], Om Gali ^[B], Suraj Haral ^[B]

^[A] Associate Professor, Dept. of Electronics and Telecommunication Engineering, MMM College of Engineering, Pune, India

^[B] U.G. Student, Dept. of Electronics and Telecommunication Engineering, MMM College of Engineering, Pune, India

Email _atharvaal432@gmail.com, omgali.1111@gmail.com, haralsuraj1106@gmail.com

DOI- <https://doi.org/10.55248/gengpi.4.523.44420>

ABSTRACT—

In this contemporary dynamic automated world, every product is smart and mechanized, all of the human desires are met with the aid of using shrewd gadgets. The automatic vending machine presents the packed meals items. These systems are operated with mixture of manually operated transfer buttons in conjunction with RFID tag. This task is achieved by the use of machine which operates on four independent servo motors as an actuator with recognize to the Arduino Uno and Atmega 328.

1. INTRODUCTION

A vending machine is an automated device that allows customers to make purchases of things such as snacks, drinks, and other items through the input of cash, a credit card, or alternative specially crafted RFID cards into the machine. In many nations, food vending machines are a prevalent method of automated, low-maintenance, low-cost product distribution.

The Vending machine is an automated gadget that serves and dispenses packed meals items and products. The project introduces the system working with the wireless transactions using RFID tags as storing traditional currency such as banknotes and coins can be a limiting factor as storage space is a crucial issue in small vending machines. The additional features added to RFID virtual machines are security and convenience. This technology allows access only via RFID, which prevents the machine from being misused.

1.1 Components of Automatic Vending Machine

Following are the components:

AVR Microcontroller (ATmega328), RFID reader, Servo Motors, LCD display 16*2, Regulator 7805, Buck converter.

2. LITERATURE SURVEY

In [1] the author Sarika Oundhakar has explained about all-encompassing solution to an individual looking for immediate symptomatic relief for trivial health problems. By relieving small symptoms at work, it can completely eliminate both present and absent the workplace. It can also decrease the current costs of open medicine cabinets. Workplaces without clinics or pharmacies can gain from enhanced productivity and prevent underperformance of sick personnel by installing an over-the-counter vending machine. Additionally, it avoids wasting hours of time waiting in waiting lists at clinics for trivial conditions like colds and headaches. This predicament is made worse by the presence of a localised disease or pandemic in a certain area.

The method used by author Malashree.G in [2] is creating All Time Medicine (ATM). This is a machine which delivers the medicine in emergency cases and ensure availability of drugs 24x7 and hence the name "All Time Medicine". ATM will be very useful in saving life in case of an accident on highways, remote areas, rural areas and places where medical stores are not within the reach in case of emergency. At least first aid can be made easily accessible with the help of this system. The Advanced RISC Machine PIC microcontroller used in this project is what drives the other subsystems, including the RFID Reader, GSM, medication dispenser, and inventory control. The unique user is identified via an RFID tag. When a prescription has to be refilled, GSM notifies inventory control. The portion of the machine that stores the medicine is called the medicine dispenser.

J.Paruvathavardhini, the author, explains how individuals in commercial areas might use autonomous vending machines to meet their basic requirements in [3]. The vending machine is based on 'EMBEDDED SYSTEM', the usage of this machine is inevitable and its demand is increasing rapidly. In today's hectic world, people often forget to bring their own vital necessities with them and instead choose to buy the items locally, turning to vending machines to satisfy their craving. But nowadays, many would rather employ digital payment methods than carry cash because of the cashless nature of doing so. In order to reduce the demand for modern payment methods, a digital payment system using RFID tags has been implemented. This system restricts access

to just RFID-enabled devices to prevent machine abuse. Here, they have created a vending machine for educational facilities that kids may use to purchase necessities like feminine hygiene products, masks, and first aid supplies. The remainder of the amount plus the remaining product numbers will be displayed in the LCD display.

The author Vishal Tank explained in [4] that access to primary health care is an important pillar of development to build a healthy future. This is achieved by machine. The communication between the Raspberry Pi and the Arduino controllers is serial via a USB cable. Power supply via a normal 230 V socket (alternating current). Due to the physical and infrastructural limitations of setting up a medical camp in remote areas, this machine was designed as a self-contained unit that requires minimal supervision to operate over long periods of time

The method used by Rajani Karalgikar in [5] describes the use of a vending machine to dispense water. The machines are the ones that dispense the water for free. Flowing substances like water, oil, food, drink etc. To help the public, the government had already created the facility to provide clean drinking water with the coin-based water dispenser, where by inserting a coin, the system dispenses the purified water on demand. This project uses RFID technology, the non-contact technology used to uniquely identify the person or object using the unique code in tag.

In [6] Govind Sopan Waghmare describes how important feminine hygiene is and the need of buying sanitary napkins in medical supply stores and other shops. One solution to this problem is to install a sanitary napkin dispensing system. People in an emergency without going to a pharmacy. It is a microcontroller and motor-based system for dispensing medication when accessed by the user via an input event. Aims to install automatic sanitary napkin dispensers in toilets and places such as long highways and remote tribal areas by using an online payment gateway. This increases the availability of sanitary napkins in the system at once, so no need to fill the napkins in the system regularly.

3. PROPOSED METHODOLOGY

The methodology of the RFID reader and key in a vending machine system is essential for facilitating user interaction and item selection. The RFID reader plays a critical role in reading the unique identification (UID) number stored on the RFID card. The process begins with providing a stable power supply to the RFID reader module and connecting the antenna for signal transmission. The reader is then initialized by configuring communication protocols and other parameters.

Continuously scanning for RFID cards, the reader detects their presence within its range. Upon card detection, the reader reads the UID number by sending a command to the RFID card, which responds by transmitting its UID back to the reader. The received UID is processed using the connected microcontroller or software, allowing for tasks such as storing the UID in a database or comparing it with existing records.

The key serves as the user interface, enabling users to make selections. Integrated into the vending machines microcontroller or control circuit, the key is monitored for key press events using code or algorithms. Upon detecting a key press, the microcontroller initiates the corresponding operation, such as dispensing the chosen item from the appropriate chamber. Visual indicators or audio signals provide feedback to the user, confirming the registered key press and ongoing operation.

The methodology ensures accurate card detection, UID reading, and seamless operation of the vending machine. By following these steps, the system enhances user experience, enabling convenient and efficient item selection in the vending machine. Block Diagram is shown in fig.1.

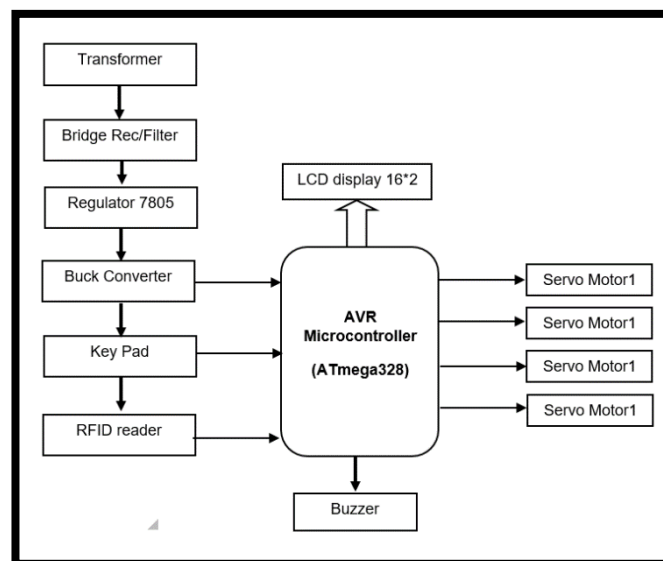

Fig. 1: Block Diagram of Automatic Vending Machine using RFID

3.1 GUIDELINE OF THE OPERATION

The RFID reader creates an electromagnetic field at a frequency of 125 kHz, which powers latent RFID transponders. These transponders have built-in antennas tuned to the same frequency. When they come within range of the reader, they draw power from the electromagnetic field to activate their internal devices.

Once powered, the transponders can modulate the incident magnetic field, which is detected by the reader. As a consequence, the reader is able to get data from the transponders. Varied transponder types with varied capabilities and data transmitting limits were developed for operation at various wavelengths each with different capabilities and the amount of data they can transmit.

The RFID reader creates an electromagnetic field at a frequency of 125 kHz, which powers latent RFID transponders. These transponders have built-in antennas tuned to the same frequency. When they come within range of the reader, they draw power from the electromagnetic field to activate their internal devices.

Once powered, the transponders can modulate the incident magnetic field, which is detected by the reader. This allows the transponders to send their data to the reader. There are different types of transponders designed to operate at various frequencies, each with different capabilities and the amount of data they can transmit.

During operation, the reader continuously scans for any transponders within its range and retrieves their data. As EM4100-compatible transponders do not have collision avoidance algorithms, only one card can be read at a time within the range of the reader. When a transponder is read, the reader decodes the received data and transmits it in ASCII format.

4. SOFTWARE DEVELOPMENT

The flow chart in fig.2 shows the working of the embedded system with respect to automated vending machine.

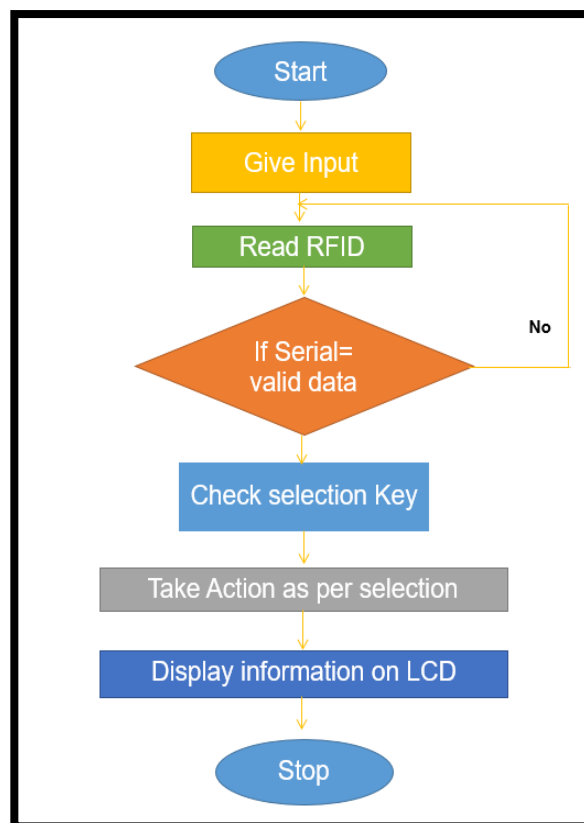

Fig 2: Flow Chart

5. HARDWARE AND EXPERIMENTAL SETUP

The circuit diagram Fig.3 contains pin configuration interfacing unit to which servo motors are connected to the PD4, PD5, PD6, PD7 and LCD display is connected to digital pins of controller Port B. The power supply of system contains the transformer and regulator 7805 which gives fixed 5v for microcontroller. Fig.4 shows complete experimental setup.

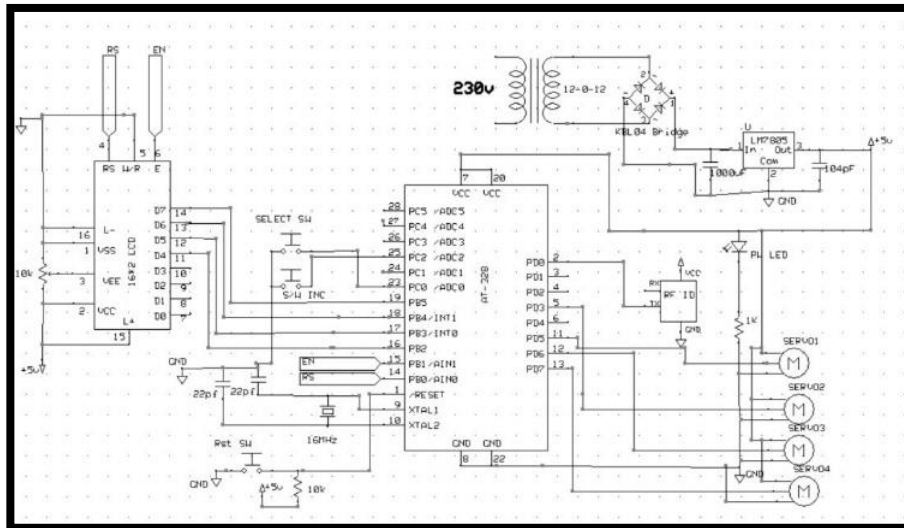

Fig.3: Circuit Diagram

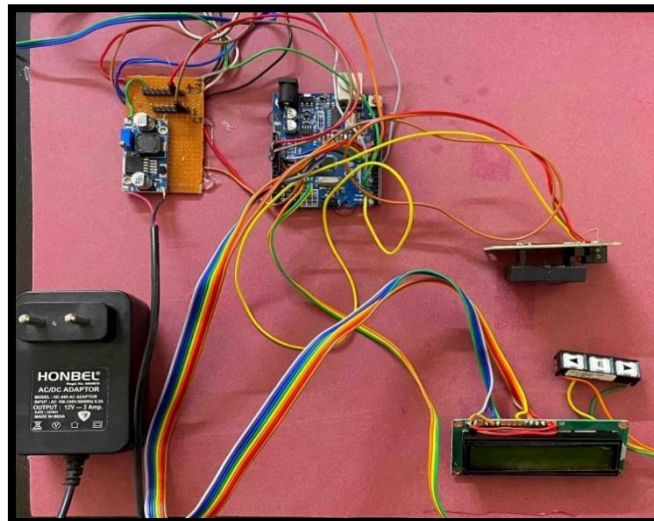

Fig.4: Experimental Setup

6. RESULT

The vending machine incorporates an Arduino Uno microcontroller as a sophisticated control system, together with an RFID tag and reader. This system features four chambers for dispensing items, with each chamber equipped with a continuous rotation DC motor positioned behind it. When a user inserts an RFID card into the candy machine and presses the corresponding button, the associated DC motor rotates, allowing the dispensing of one item. Coils made of material holder wires are connected to the DC motor, facilitating the release of the item during the motor's rotation. Once the motor reaches a fixed point, the items become accessible to the user at the output of the candy machine. The LCD display provides information such as the insertion of the RFID card, item selection, and account balance. Users possess passive RFID cards operating at a frequency of 13.56 megahertz. When a purchaser places their RFID card within range of the RFID reader, the stored unique identification (UID) number on the card is read by the RFID reader. The Arduino programming utilizes this UID number to establish a database for each RFID user, storing details such as the user's identity, current balance, and post-transaction balance associated with the card. The LCD display shows the current count.

If a user selects an item by pressing the corresponding button, metal springs are activated, allowing the item to be retrieved at the candy machine's output, and the remaining balance is displayed on the LCD screen. In this system, users are required to Insert an RFID card and press a button of their choice to receive the corresponding item.

The RFID-based vending machine primarily employs four hardware components: Arduino Uno, two continuous rotation DC motors, an LCD display, an RFID card, and a 12V power supply. Two buttons are provided for selecting items in the respective chambers, while the LCD display provides instructions and messages for operating the machine. This system is portable, cost-effective, energy-efficient, and easily accessible, enabling users to utilize it conveniently and at their convenience. Final product is shown in fig.5.



Fig.5: Final Product

7. CONCLUSION

In summary, the RFID reader emits an electromagnetic field that powers transponders within its range. The transponders modulate the magnetic field to transmit their data to the reader. The reader scans for transponders and retrieves their information, transmitting it in a readable format. The presented framework requires the customer to insert an RFID card and select an item by pressing a designated button, upon which the vending machine will dispense the corresponding product. This RFID based vending machine utilizes four essential components: an Arduino Uno microcontroller, four durable constant rotation DC motors an LCD display, an RFID card, and a 12V power supply. Two buttons are provided for item selection in the respective chambers, while the LCD display conveys messages and provides instructions for operating the machine. The system is designed to be versatile cost-effective, energy-efficient, and easily accessible, allowing customers to utilize it at their convenience respectively.

8. REFERENCES

- [1] "Automatic Medicine Vending Machine", Sarika Oundhakar, India International Journal of Engineering Technology Science and Research IJETSRS ISSN 2394 – 3386 Volume 4, Issue 12 December 2017.
- [2] "AUTOMATIC MEDICINE VENDING SYSTEM-MEDICAL ATM" M Sangeetha, T V Janardhan Rao, Ch. S Rama Gowri, ISSN: 2455-2631© October 2016 IJSDR | Volume 1, Issue 10 IJSDR1610031 International Journal of Scientific Development and Research (IJSDR).
- [3] "ATM (All Time Medicine) Counter for Medicine Self-Dispensing", Malashree.G, Ubaidulla, Shilpa R S, Divya U, International Journal of Latest Technology in Engineering, Management & Applied Science (IJLTEMAS) 1st Special Issue on Engineering and Technology | Volume VI, Issue VS, May 2017 | ISSN 2278-2540.
- [4] "Autonomous All Time Medicine Counter for Medicine Self Dispensing", Srividya C N, Munisahana M, Navyashree N S, Nikhil Gowda T K, May-2019, www.ijraset.com, (IJRASET).
- [5] "Medicine Dispensing Machine Using Raspberry Pi and Arduino Controller", Vishal Tank, Sushmita Warriar, Nishant Jakhiya, IEEE Conference on Emerging Devices and Smart Systems, March-2017.
- [6] "Automatic Medicine Vending System-Medical ATM", M Sangeetha, T V Janardhana Rao, Ch Rama Gowri, IJSDR, October-2016, www.ijdsdr.org.
- [7] "The Autonomous Pill Dispenser with Alarm and Mobile Notifications", Jayesh Patil, Sameer Khairmode, Rishikesh Lokhande, Omkar Shinde ISSN: 2321-9653, IJRASET, www.ijraset.com, April-2019.

-
- [8] “*Solar Powered IOT Based Intelligent Sanitary Napkin Dispenser*”, K.Samba Siva Rao, K.Harish, M. Kavin Kumar, D. Vishnu Harish, March 2018, International Journal for Research in Applied Science and Engineering Technology (IJRASET), ISSN:2321-9653, Vol-6, Issue 3,pp.2016-2021.
- [9] “*Design and Fabrication of Automatic Dispensing Machine*”, Mohan Sukragond, Prafullachandra P Siddeshwar, Pradhyumna D R, Prajwal Setty, International Journal of Research in Advent Technology, Special Issue may-2018, 3rd National conference on Emerging Trends in Mechanical Engineering (NCETM2018) Available online at www.ijrat.org, pp.20-26.
- [10] “*Automatic Paper Vending Machine*”, Kamalanathan.P, Irshath Ahmed, Mohamed Aamir, Kalaiselvan.P, April 2015, International Journal of Science, Engineering and Technology (IJSETR), volume 4, Issue 4, pp.634-639
- [11] “*Case Study on Different Vending Machines*”, Asmita P. Bodhale, Prof.J.S. Kulkarni, April 2017, International Research Journal of Engineering and Technology (IRJET) e-ISSN: 2395-0056, p-ISSN: 2395-0072 Volume: 04 Issue: 04, pp.3531-3535`