



Autonomous Intelligent Vehicle

Prof. Sunil Khot¹, Mr. Pratik Edake², Ms. Sayali Patil³, Mr. Rohit Shinde⁴

^{1 2 3 4} Department of Electronics and Telecommunication SCTR's Pune Institute of Computer Technology Pune, India

ABSTRACT –

Autonomous cars are smart cars that are expected to be driverless, efficient, and crash-free ideal urban vehicles in the near future. The future of autonomous vehicles will be extensive network guided systems working in conjunction with vision guided features and other sensory systems. In modern vehicles, we can see varying levels of automation where the vehicle can drive itself, while others can only have some level of automation. AIVs (Automated Intelligent Vehicles) guarantee a safe, comfortable, and efficient driving experience. However, fatalities involving AIV-equipped vehicles are on the rise. The full potential of autonomous intelligent vehicles will not be realised unless the robustness of current technology is improved further. For this project, we want the AIV to choose his path based solely on the destination. We created this using a Raspberry Pi 3 and the Ubuntu operating system. Our project is based on creating an autonomous intelligent vehicle that can decide for itself which path to take and avoid any obstacles that may be in its path. A map of the room in which the vehicle is present would be stored on the single board computer (Raspberry Pi). The user will provide the bot's starting coordinates, and the Raspberry Pi will collect and perform all necessary calculations before proceeding to the destination.

This paper discusses unresolved issues and provides a technical overview of automated driving. Current challenges, high-level system architectures, emerging methodologies, and core functions such as localization, mapping, perception, planning, and human-machine interfaces were thoroughly examined. Furthermore, many cutting-edge algorithms were implemented and tested in a real-world driving environment on our own platform. The paper concludes with a discussion of the datasets and tools available for AIV development.

Introduction

With each passing day, the world develops new technologies and advanced automation systems. People began working on Autonomous Driving in 1925, and many advances have been made in that field since then. However, the technologies still require human assistance with a certain level of judgement. The ongoing research is primarily focused on driverless vehicles that require no human intervention. An autonomous vehicle will be able to make its own decisions.

As reported by Automobile Engineers, autonomous vehicles are classified into six different levels.

The first level is Level 0 in which the vehicle doesn't have any automated driving technology and the driver is responsible for all decisions.

Second is Level 1 which consists of one or more assisted driving technologies such as parking sensors, etc.

Third is Level 2 which contains two or more technologies that work together simultaneously.

Fourth is Level 3 which has limited technologies for automation driving functionality. In which the vehicle itself can make its own certain decisions using the sensors such as Lidar.

Fifth is Level 4, in which the vehicles consist of fully automated driving technologies. Under selected conditions, human oversight is required.

Last is Level 5 where the vehicles are fully automated and don't require human involvement. The vehicle itself is responsible for all the driving decisions and tasks.

These levels are shown in the below figure.

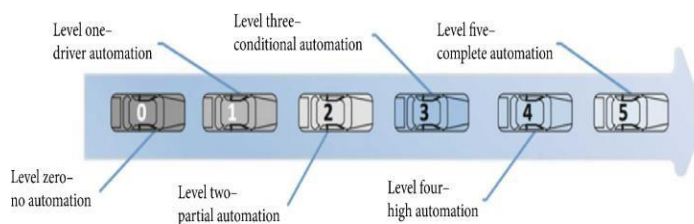

Fig. 1. Levels of AIV described by Automobile Engineers

Despite the fact that many companies, including Google, Tesla, and Uber, have invested heavily in the development of this technology, the autonomous vehicle system remains an active and interesting research area due to its significant challenges. A good autonomous vehicle system is one that can make correct decisions brilliantly in real time. Researchers are still working hard to develop better algorithms for localization and detection.

Autonomous intelligent vehicles can sense their surroundings by utilising various sensors mounted on the vehicle itself. The information gathered by these sensors is then used to make decisions such as the safest route to take to reach the destination while keeping the time and distance requirements in mind. Localization, path planning and object detection, as well as data combination from various sensors, are required to complete the piece of work.

With the availability of extremely powerful computing tools such as Graphics Processing Units (GPUs) and a large amount of data, a branch of Artificial Intelligence known as Deep Learning (DL) has grown in popularity as a means of solving these problems and achieving the best performance. Deep Learning algorithms have improved AIV performance by ensuring accuracy and speed of processing. This paper examines various technologies used in autonomous intelligent vehicles. It is discussed the general structure of Autonomous Vehicles (AVs). The techniques used for localization as well as path planning are discussed.

Localization in AIV

Autonomous vehicles must be able to recognise the environment and be able to locate themselves in the environment correctly. This section evaluates various techniques for object detection and localization implemented in the literature survey.

Hardware: Cameras or LiDAR for sensing

3D recognition is commonly used to gain a better understanding of the surrounding environment. LiDAR sensors are commonly used for 3D recognition. Images captured by cameras can only depict a two-dimensional environment. The performance of a LiDAR is measured by its range, resolution frame rate, and field of view. Velodyne is a 360° field-of-view 3D sensor. Autonomous intelligent vehicles cannot afford any setbacks or delays in information communication, so a minimum range of 200 metres is required for processing at extremely high speeds.

The debate over LiDAR technology or cameras remains an intriguing topic. Waymo's vehicle technology, for example, is based on LiDAR, whereas Tesla uses a camera system for environment recognition. Every sensing method has advantages and disadvantages. LiDAR is a technology that ensures high resolution and accurate environment perception but performs poorly in adverse weather conditions. Furthermore, cameras are inexpensive, perform poorly in adverse weather conditions, and have very poor depth recognition. On the other hand, LiDAR technology is currently prohibitively expensive. Radar and Ultrasonic sensors, in addition to cameras or Lidar, are used to improve the system's perception capability. Waymo employs three LiDAR sensors.

The Comparison based on LIDAR and Camera from the various literature survey is given below:

Table No. 1

Sr. No	Author	Component used	Description
1.	Amit Kumar Tyagi,	LIDAR	LIDAR gives 360-degree representation. LIDAR framework can similarly be
	S U Aswath		placed on top of the vehicle to get 3D points which are away from the zone.

2.	Syed Saad ul Hassan	LIDAR	Lidar (Light detection and ranging) is key component for Autonomous driving architecture. It holds the decision for current AVs (autonomous vehicles) because of two important characteristics Object detection and Depth approximation. It has several applications in robotics, due to its accuracy and high sensitivity,
3.	Daria Belkouria, Richard Lainga, David Graya	Camera with 3D Laser Scanner	Three-dimensional (3D) laser scanning technology has been widely used in AVs to perceive their surroundings and collect physical environment information in real time, track obstacles after detecting them, boundaries, other cars, and so on. Laser scanning technology, which allows for rapid and precise spatial data acquisition, documentation, and mapping, is also widely used in architecture, 3D printing, engineering, construction, surveying, archaeology, and built heritage.
4.	Ze Liu, Yingfeng Cai, Hai Wang & Long Chen	LIDAR and RADAR Fusion	Radar and LiDAR data are effectively combined to achieve high-precision detection of target speed and location around the autonomous intelligent vehicle. The results of this paper show that the proposed sensor combined method can detect and track vehicle targets with high accuracy. It has obvious advantages over a single sensor and can improve the intelligence level of autonomous vehicles.
5.	Vedant Rane, Hrithik Poojari, Prasan Sharma, Soham Phansekar,	LIDAR	LiDAR technology offers more detailed and in-depth solutions than other technologies like cameras and radars. It can also be used at night. LiDAR-created maps from suppliers are updated quarterly, providing the data

	PrajaktaPawar		for the rest of the vehicle's sensors and computers to drive confidently without much driver intervention. LiDAR fills in the gaps left by other sensors.
6.	<u>Mahdi Elhousni</u> , <u>Xinming Huang</u>	LIDAR	LiDAR sensors are quickly becoming one of the most important sensors for self-driving cars. LiDARs can generate rich, dense, and precise spatial data, which can be extremely useful in localising and tracking a moving vehicle. In this paper, we review the most recent findings in 3D LiDAR localization for self-driving cars and analyse the results obtained by each method in an effort to direct the research community towards the most promising path.
7.	Mr. Ritik Rokade, Mr. Nikikesh Sonwane, Mr. Sanjay Bisen	LIDAR	The spinning LIDAR sensor mounted on the vehicle's roof is a very distinctive component in a self-driving vehicle. This is a key component in self-driving vehicles because it collects data about the surroundings to allow navigation systems to safely guide the vehicle.

Table No. 2

Performance aspect	Human	LIDAR	Camera	RADAR
Object detection	Good	Good	Fair	Good
Object classification	Good	Fair	Good	Good
Visibility range	Good	Fair	Fair	Good

Distance estimation	Fair	Good	Fair	Good
Weather performance	Fair	Fair	Poor	Good
Lane Tracking	Good	Poor	Good	Poor

Localization

Localization is the function or task of determining the vehicle's position (orientation + position) as it moves through its surroundings. Localization is required for navigation purposes. It is worth noting that some of the most recent trending researchers in Autonomous Intelligent Vehicles have proposed Deep Learning-based algorithms that do not require any localization or mapping. Instead, it generates end-to-end driving decisions based on sensor data. This is known as the Behaviour Reflex approach. GPS, or Global Positioning System, is the most commonly used technology for localization in Autonomous Intelligent Vehicles. GPS data is combined with data from other sensors to compensate for signal loss in the event of an interruption. This method of localization is known as Visual Odometry (VO). To achieve Visual Localization, key point landmarks are matched with adjacent video frames. The input, which is key points, is fed to the n points mapping algorithm, which is used for position detection with respect to the previous frame, based on the vehicle's current frame information.

Deep learning techniques can improve the accuracy of visual odometry. These algorithms may have an effect on the precision of the key point detector. A DNN is trained for key point distraction learning in monocular VO. Another method for incrementally mapping the structure of the surroundings is to compute the camera posture. This method is SLAM-related (simultaneous localization and mapping).

SLAM is the process of simultaneously creating an online map and locating the vehicle on it. In SLAM, no a priori knowledge of the surroundings is necessary. Deep learning approaches have significantly improved picture classification and detection; hence these algorithms are advised as a supplement to conventional SLAM algorithms. Although deep learning applications in this sector are still in their infancy, several research have suggested that in order to improve accuracy and resilience, the traditional SLAM blocks could be replaced with deep learning modules.

AIVs should be able to anticipate the motions of their surroundings in order to ensure safe navigation. Scene flow is the name for this. The estimation of the scene flow using LiDAR is a common strategy in the literature. According to recent research, the method should be replaced by Deep Learning algorithms for automatically learning scene flow.

Path Planning

Path planning comes next when an AIV is able to localise itself in the environment. The capacity of autonomous vehicles to choose the best route between their starting place and their destination (i.e., the desired location) while taking into account their kinematics and dynamic model is known as path planning. The path planning procedure should provide the autonomous vehicle with the ability to choose the best trajectory to guarantee a collision-free path while taking into account any potential impediments it might encounter in the surrounding area.

Any time the host vehicle performs an action like making a turn or changing lanes, it must be able to and deploy effective negotiation abilities with all other road users. The entire pursuit of the created path by path planning is referred to as mission planning.

Mission, motion, and behaviour planning are also included in path planning. Big data is a term used to describe the enormous amount of data that is kept on the server each time the car is put through a driving experience. AIVs can utilise the knowledge found in previously stored data to decide wisely in the future. Due to all the obstructions in the way of the vehicle, route finding algorithms are quite difficult. These barriers complicate the job of the planning algorithm, so the AIV should be able to identify them as well as avoid them. The AIV needs to be fully aware of what to do in various driving circumstances.

Graph Search-Based Planning Techniques

The fundamental principle behind the autonomous driving path planning approaches is to travel the entire state space from source point A to goal point B. The state space, which identifies the locations of items in a dynamic environment, is typically depicted as a lattice or an occupancy grid. The graph

search methods traverse the state space in the occupancy grid and, if an optimal or suboptimal solution is found, return it; otherwise, they provide no solution at all. The following is a description of the most popular search algorithms used for path planning by autonomous vehicles.

Dijkstra Algorithm

Finding the shortest path through a grid or collection of nodes is done using a graph search method. It performs effectively for both structured and unstructured environments' global path planning. The technique has been used in multi-vehicle simulations, though. Despite its benefits, the algorithm is sluggish because a lot of nodes must be traversed in the huge areas. Additionally, the algorithm makes no use of any heuristics to reduce the cost of the search. Since the path was not obtained continuously, real-time scenarios cannot be used with it.

A-Star Algorithm

Heuristics are used to ensure optimality and speed up node searches, extending the Dijkstra method and speeding up computing. The A-star algorithm has the benefit of calculating the cost before defining the node weights. While it is expensive in terms of speed and memory for scanning vast areas, it is ideal for searching places that the vehicle is theoretically familiar with. A-star is used in mobile applications like the dynamic () and anytime repairing in various customised forms (). Voronoi cost functions have been implemented for path planning in parking lots and unstructured areas. The AD* algorithm was utilised by the Boss, who won the DARPA Urban Challenge. Despite its benefits, the A-star algorithm's route is not continuous. Furthermore, it might occasionally be exceedingly difficult to identify the heuristic rule.

Sampling-Based Planning Techniques

This method operates by randomly sampling the state space or configuration space and attempting to find connectedness inside the space. These methods make use of higher dimensional planning to address temporal constraints. However, the methods produce less than ideal answers. The Probabilistic Roadmap Method and Rapidly- Exploring Random Tree (RRT) are the two most popular sampling- based methodologies (PRM). While RRT is substantially faster than PRM, both are probabilistically complete. For online path planning, RRT is utilised. In order to quickly plan in semi-structured spaces, it does a random search in the navigation space. The MIT team utilised the algorithm in the DARPA Urban competition for autonomous vehicles. However, the resulting path is uneven, discontinuous, and unsatisfactory. This algorithm's modified version, known as RRT, is explained. The generated answer is the best one, but at the expense of computational effectiveness.

Interpolating Curve Planning Techniques

A fresh collection of data points that fall within the range of previously known data points is referred to as interpolation (reference points). These algorithms create fresh data points from known waypoints that outline a global route. The points produced guarantee a smooth and continuous trajectory and are also advantageous for the AIV limitations and the dynamic environment in which it moves. If an obstacle is encountered while the path is being executed, it generates a new set of data points to get around it before continuing on the original path. Curve creation and path smoothing employ a variety of strategies, some of which are discussed here.

1. Lines and Circles

Segments of various road networks can be represented by interpolating known waypoints with circular and linear/straight shapes. It is computationally cheap and simple to implement. It ensures the shortest path for automobiles. However, the generated path is jerky, resulting in uncomfortable transitions between path segments. Global waypoints are also required.

Other than the techniques given above, there are various methods for path planning and those methods are compared below:

Table No. 3

Method	Global Path	Local path	Dynamic Obstacle	Static Obstacle	Computational Time	Path smoothness	Path cost
A*A	Yes	No	No	Yes	High	Yes	Low
AI	Yes	Yes	Yes	Yes	High	No	Medium
RRT	Yes	Yes	Yes	Yes	High	No	High
RM	Yes	Yes	Yes	Yes	Medium	No	Medium
LS	Yes	Yes	Yes	Yes	Low	No	Low

Geared DC Motor

DC Geared Motor will be used for driving the Wheels of the bot. There are various DC geared motors but according to our literature survey the mostly used motor in Autonomous Intelligent Vehicle is SPG30E. This motor compared with the other motors have the perfect and suitable specifications which will drive our AIV.

Obstacle avoidance

For autonomous driving to be successful, automated vehicles must navigate a number of path modifications. When an obstacle gets in the way of the original path, an automated vehicle must frequently determine its own path. If an obstacle is moving, it could be stationary or in a collision path. To avoid the obstacle, the automated vehicle must consider the vehicle model and the environment map to determine the shortest path back to the initial path while maintaining a minimum clearance to surrounding obstacles. To accomplish this, decision algorithms are used to divide the map into grids. When running tree exploration solutions, decision algorithms operate with varying degrees of efficiency.

What have we understood from that?

Autonomous Intelligent vehicle is a vehicle which can determine the whole journey from source to destination with/without any help from the person. It is a vehicle which traces its path from its source to destination point by determining the optimum path and continuously avoiding the obstacles in its path to deliver a safe and driverless journey. It is a vehicle which can sense its environment and navigating without human input. Implemented control systems interpret information from the mounted sensors to determine appropriate navigation paths, evade obstacles and identify relevant path.

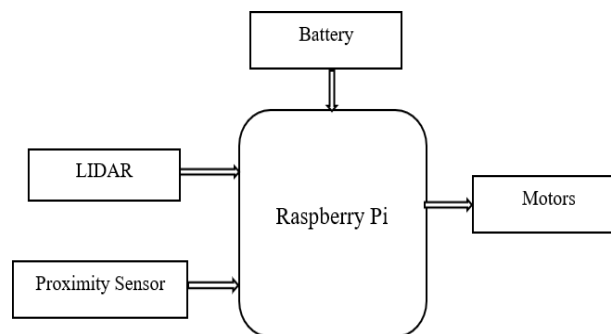

Fig. 2. Block Diagram

According to our survey regarding the Autonomous Vehicle, we have come to know that compared to other algorithms SLAM algorithm is mostly used for the Localization and mapping. It is best suitable for navigating the robot in the surrounding area. There are various techniques for the localization in Autonomous Intelligent Vehicle which we have compared in this survey paper after going through the various literature surveys. According to this survey, we have decided to use the following components and algorithms in our proposed system:

Raspberry pi 3B, LIDAR, SLAM Algorithm, Sampling based planning technique for Path Planning, Geared Motor.

Applications

AIVs for Logistics

While autonomous vehicles' capabilities continue to advance, the most basic and widely used application for these machines is material transport. AIVs can transport orders multiple times per day across a warehouse or through a shipping facility. Transportation is a labour-intensive job, and using robots for these tasks is one of the simplest ways to free up human workers for more important tasks while minimising disruptions to workflows.

Heavy Machinery

Autonomous vehicles are transforming industries such as agriculture, mining, and construction in a variety of ways. Companies benefit in a variety of ways when large machines can see and work in a variety of conditions for extended periods of time.

Automation in Farming and Agriculture

Individuals operating large farming machinery, like truck drivers, are susceptible to exhaustion and risk. In these environments, self-driving vehicles can work longer hours than humans, allowing people to rest or eliminating the need for labour-intensive tasks like tilling or harvesting. Efforts can then be focused on other critical areas.

Eliminating the need to stop or delay operations due to weather conditions also allows businesses to continue operations while protecting their workers' safety. In extreme weather conditions, LiDAR technology assists machines in identifying obstacles, people, and even automatically stopping and restarting operations to maintain efficiency and productivity.

Automation in Construction and Mining

Even before the vehicles arrive, construction and mining can benefit from the LiDAR technology used to support self-driving vehicles. Mapping out construction and mining sites before beginning work is critical to the project's success and safety. Unexpected underground discoveries or changes can have a long-term impact on a project, so it is best to identify and address these issues as soon as possible. Once work begins, self-driving vehicles can more effectively navigate the size of the vehicles and the complexity of construction and mining work in general. These vehicles can operate in dusty conditions, on uneven terrain, and for extended periods of time in a variety of lighting conditions, including at night, when some believe construction is better suited. While doing this type of work at night may have advantages, self-driving machines could help workers maintain optimal safety under such conditions.

AIVs for Warehousing

Today's warehouses and distribution centres are massive, with some covering more than a million square feet. When AIVs are used in warehousing automation applications, they are best suited to do heavy lifting and transport of goods throughout the space. AIVs performing basic warehousing reduces the amount of time workers spend travelling in a warehouse, allowing them to work on more value-added tasks.

One distinguishing feature of AIVs is their ability to see and locate themselves in open spaces. AIVs scan their surroundings with lasers, and their embedded systems analyse the sensor data, allowing them to see obstacles and navigate safely. However, massive warehouses lack the walls, posts, and other fixed features that many AIVs require to navigate effectively. This environment necessitates the use of an AIV with a navigation system specifically designed for warehouse operations.

AIVs in Healthcare

Many industries are finding innovative applications for robots as the capabilities and ease-of-use of AIVs improve. Today, more autonomous robots are being used in the healthcare field for a variety of tasks.

First and foremost, AIVs are a useful tool for streamlining supply and medication transport throughout a healthcare facility. This is especially important in infectious disease units because it keeps nurses away from potential contaminants while still ensuring that patients receive proper care. Second, medical AIVs can be used in sanitation—robots can be outfitted with virus-killing UV lights or decontamination sprays to clean up a room or space without endangering people.

Future Scope

Along with the convenience of not having to drive, autonomous cars are said to be safer. That is, if human error is responsible for up to 94% of all road accidents, according to the National Highway Traffic Safety Administration, perhaps it makes sense to rely more on technology to keep us safe. In an accident caused by potentially dangerous human behaviours or conditions such as speeding, reckless driving, drowsiness, distracted driving, or impairment

due to alcohol or drugs, a driverless car will not endanger its driver or others. Because autonomous vehicles can communicate with one another and change routes based on traffic, accidents, or construction, they may reduce road congestion.

The concept of autonomous driving has sparked a lot of interest and attention in recent decades because it is thought to provide numerous benefits for individuals and society, including increased road safety, reduced traffic congestion, accidents, and death, and time and pollution savings on commuting. There will be the most successful evolution of self-driving vehicles in the coming future, with industries designing and developing cutting-edge LiDAR technology, among other things, to help make the future of self-driving vehicles a reality. AI could be used in the future to create self-driving cars, as well as cars that can communicate with one another and other road users.

The automotive industry has already been significantly transformed by automated and autonomous vehicle technology, and there is still much more to be done. It will take time to fully integrate self-driving vehicles on roads, in warehouses, in fields, and elsewhere. Along the way, there will be several other considerations to address, such as changes in the insurance landscape and technologies as more automated and autonomous vehicles coexist with humans in various working environments.

Conclusion

We have provided a review of the various technologies that can be used in the technology of autonomous vehicles in this paper. One of the most important issues in vehicle design is the creation of intelligent and efficient algorithms for the safe operation of AVs. This work depicts the entire layout of an autonomous vehicle. A survey of various cutting-edge AI algorithms used by AVs to achieve the best possible and optimal solutions to the problems of localization, path planning, and distance measurement hardware has been presented. Although the field of AVs is vast and involves a widerange of challenges to address, the problem's very challenging nature creates an endless number of research opportunities in this field.

REFERENCES

1. Autonomous Intelligent Vehicles (AIV): Research statements, open issues, challenges and road for future. January 2021, License: [CC BY-NC-ND 4.0](#) https://www.researchgate.net/publication/354049190_Autonomous_Intelligent_Vehicles_AIV_Research_statements_open_issues_challenges_and_road_for_future
2. Lidar Sensor in Autonomous Vehicles. March 2022 https://www.researchgate.net/publication/359263639_Lidar_Sensor_in_Autonomous_Vehicles
3. Vision-Based Autonomous Vehicle Systems Based on DeepLearning: A Systematic Literature Review <https://www.mdpi.com/2076-3417/12/14/6831/pdf>
4. Intelligence of Autonomous Vehicles: A Concise Revisit. Volume 2022 | Article ID 2690164 <https://www.hindawi.com/journals/js/2022/2690164/>
5. Autonomous Vehicles and Intelligent Automation: Applications, Challenges and Opportunities. Volume 2022 | Article ID 7632892 <https://www.hindawi.com/journals/misy/2022/7632892/>
6. Towards a Viable Autonomous Driving Research Platform https://www.ri.cmu.edu/pub_files/2013/6/2013_IV_SRX.pdf
7. Research on Comparison of LiDAR and Camera in Autonomous Driving <https://iopscience.iop.org/article/10.1088/1742-6596/2093/1/012032/pdf>
8. Through the eyes of Autonomous Vehicles – using laser scanning technology <https://www.sciencedirect.com/science/article/pii/S2352146521009650>
9. Surrounding Objects Detection and Tracking for Autonomous Driving Using LiDAR and Radar Fusion <https://cjme.springeropen.com/articles/10.1186/s10033-021-00630-y>
10. Lidar based self-Driving Car <https://www.ijraset.com/research-paper/lidar-based-self-driving-car>
11. A Survey on 3D LiDAR Localization for Autonomous Vehicles <https://ieeexplore.ieee.org/document/9304812>
12. THE SELF-DRIVING CAR USING LIDAR <https://ijcrt.org/papers/IJCRT2106279.pdf>