



Vehicular Communication System Using RF Technology with Mesh Network

Subodh Yelgandharwar¹, Vaishnavi Trikal², Rushikesh Waghmare³, Ashwini Jadhav⁴

^{1,2,3}Final Year Student, Department of Electronics and Telecommunication Engineering, Sinhgad College of Engineering, Pune, Maharashtra, India

⁴Project Guide, Department of Electronics and Telecommunication Engineering, Sinhgad College of Engineering, Pune, Maharashtra, India

ABSTRACT

The purpose of this paper is to address the pressing road safety issues that plague our country. Unfortunately, a high number of fatalities result from accidents on the road. To combat this problem, this paper proposes the implementation of a Vehicle-to-Vehicle (V2V) communication protocol that will allow vehicles to communicate wirelessly with one another while on the road. This protocol will use Radio Frequency (RF) communication, which has a range of 100 to 300 meters depending on the module and antenna utilized. V2V communication is especially crucial in areas with no internet connectivity or Global System for Mobile (GSM)-based communication. It enables vehicles to communicate data such as accidents, vehicles ahead, vehicles coming from opposite lanes, and other warnings. The NRF module is utilized to establish wireless RF communication between vehicles. The NRF modules present in both vehicles communicate with one another and transmit messages over a wireless medium. This type of communication is much more reliable than internet or mobile-based communication. A Node MCU microcontroller integrates all the sensors present, controlling all the functions. This technology plays a vital role in preventing accidents on roads, which remains one of the most significant issues in our country, causing numerous fatalities. Connected vehicles on the roads provide smoother traffic, tackle congestion, and in case of any human error, the vehicle can communicate with other vehicles quickly and wirelessly, cautioning the other driver, thereby avoiding fatalities.

Keywords: Vehicle to Vehicle Communication, NRF

1. INTRODUCTION

1.1 Significance

Accidents are one of the world's biggest problems right now. Road accidents claim the lives of thousands of people virtually every hour. The alarmingly high number of fatalities resulting from traffic accidents every day. This has grown to be a very troubling problem in a nation like India. The main reasons for accidents are due to lack of concentration while driving, not following the traffic rules, rash driving, and not knowing properly about the surrounding vehicles. If there was a mechanism for the car travelling in front to signal or warn the vehicle moving behind that there is a vehicle coming from the opposite lane or a vehicle moving beside it, the collision in the aforementioned scenario could have been prevented. This is made feasible through RF. The RF24L01 model is a wireless transceiver module with a great range that is based on radio frequency communication. It uses little power and has a single channel for sending and receiving messages.

When this kind of technology is implemented in modern vehicles it makes them smart, we can achieve V2V which is nothing but vehicle-to-vehicle communication. This will ensure that even in high traffics or tough environmental conditions the accident rate can be reduced. Additionally, in the event of a collision, a warning system will send signals to other vehicles alerting them to the situation. Because no system is error-proof, this form of alarm system is required in the event that an accident occurs.

1.2 Problem Statement

Traffic congestion is a major issue that causes accidents and takes many lives every year. The primary cause of traffic congestion is people not following traffic laws. This affects more than 60% of people during peak hours and disrupts daily life. Providing drivers with a warning half a second before diverting or blocked roads can prevent accidents and enable awareness of surrounding threats. Here introduces the paper, and put a nomenclature, if necessary, in a box with the same font size as the rest of the paper. The paragraphs continue from here and are only separated by headings, subheadings, images and formulae. The section headings are arranged by numbers, bold and 9.5 pt. Here follows further instructions for authors.

1.3 Objective

- To avoid and minimize road accidents and traffic congestion problems.

- This system is also helpful for taking certain actions/decision on the vehicle by obtaining collision warning.
- To develop a communication platform for inter-vehicle communication.
- Monitor and evaluation of driver distraction issues.
- To enable the development of safety applications by specifying, prototyping, and demonstrating of VEHICLE-TO-VEHICLE system.
- To push harmonization of VEHICLE-TO-VEHICLE Communication standards worldwide.

2. LITERATURE REVIEW

2.1 Recent Trends

LONDON, Feb. 15, 2022 (GLOBE NEWSWIRE) -- According to The Business Research Company's research report on the vehicle-to-vehicle (V2V) communication market, growing concern for road safety is expected to propel the growth of the vehicle-to-vehicle communication market going forward. Road traffic injuries cause considerable damage to infrastructure and human lives, as well as economic losses to individuals, their families, and nations. Road accidents can be prevented by improving the safety features of vehicles, designing safer infrastructure, incorporating road safety features into transport planning, enforcing laws relating to key risks, and raising public awareness. There are so many accidents taking place because of the lack of road safety and the measures taken for road safety, and there is a need for vehicle-to-vehicle communications to provide road safety. According to the World Health Organization, road traffic accidents kill over 1.3 million people each year, with low and middle-income countries accounting for 93 percent of all traffic deaths in June 2021.

2.2 Literature Survey

[1] U.S. Department of Transportation, this publication is distributed by the U.S. Department of Transportation, National Highway Traffic Safety Administration.

In general, two sets of components are needed for V2V communications to operate. The first set of components are those required for a device to transmit an accurate and trusted BSM and the second are the components needed for a device to receive and interpret a BSM transmitted from another entity (such as via a GPS antenna and receiver). To operate the safety application adequately to warn drivers, a driver-vehicle interface is needed to display critical advisories and imminent alerts.

[2] Mr. Anthonylan Smith, Penn State Harrisburg, Pennsylvania State University published a paper.

In this paper, V2V communications operation is discussed based on a wireless protocol, Dedicated Short Range Communications (DSRC). In V2V communications, every vehicle is also a router which allows for sending/receiving messages over multi-hop systems to/from other vehicles and or roadside stations. The routing algorithm is based on the position of the vehicles and can handle fast changes in the network topology.

[3] Vehicle Position and Context Detection Using V2V Communication

A pre-crash detection and warning system in a host vehicle needs to accurately determine the position of each remote vehicle in its vicinity and the context of the driving environment. ADAS (Advanced driver-assistance systems) have extensively used camera radar and LIDAR for the automatic detection of vehicles, pedestrians, and other road users and their behaviors. However, these vehicle-resident sensors have short operation ranges and require objects to be within the line of sight. V2V communication has emerged to be a promising technology to augment vehicle-resident sensors with the extended ability of an overall vehicle safety system by addressing a broader range of crash scenarios with improved warning timing. In this paper, we present an intelligent system, Geo+NN, developed using the synergy of neural networks and geometric modelling.

[4] Vehicle-to-Vehicle Communication for Crash Avoidance System

The Dramatic increase in the traffic flow raises demand for innovative technologies that can improve the safety and efficiency of transportation systems. Road safety can be substantially enhanced by the deployment of wireless communication technologies for vehicular networks, which enable new services such as collision detection traffic management, and further communication facilities between moving vehicles. Aiming at providing reliable wireless communications for vehicular networks RF communication will serve as an underlying protocol for future inter-vehicular applications worldwide. This paper presents an implementation of a complete vehicle-to-vehicle communication, designed according to the specification. In addition to this a blind spot detection system for protection against misshapen-like vehicle collisions that cause loss of human lives is being implemented.

[5] Use of Mobile Mesh Networks for Inter-Vehicular Communication

High-speed wireless computing networks are now economically feasible for home users, via 802.11b wireless protocols and their associated hardware. Such centralized "point-to-multipoint" installations typically allow a range of about 100 meters from the central access point. It is possible to use the same network protocols and hardware to construct a "wireless mesh" or "multipoint-to-multipoint" network in which any connected node can communicate directly or indirectly with any other connected node. The research project described in this article applies wireless mesh networking to inter-vehicular communication. Three vehicles were connected as a wireless mesh network using laptop computers with 802.11b radio cards and mesh

networking software. The vehicles were then driven on a highway in Northern California to collect data about network connectivity. The goal of the experiment was to prove that such a network could be quickly and easily constructed and that network connectivity could be maintained under normal driving conditions. Data was collected on network connectivity and time delay of network packet transmission.

[6] Vehicular Communication Establishment using NRF with Emergency Alert System

The purpose of this paper is to solve the road safety issues present in our country. In today's scenario, many accidents happen on roads, resulting in a huge number of fatalities. The idea is to introduce a Vehicle-to-Vehicle communication protocol that will enable the vehicles moving on the road to communicate with each other in a wireless medium. Wireless communication between any two vehicles is possible using Radio Frequency (RF) communication with a range of 100 meters to 300 meters depending on the module and the antenna used. This Vehicle-to-vehicle communication also known as V2V is essential in areas with no internet connectivity or GSM (Global System for Mobile) based communication. This established connection between vehicles is used to communicate data like accident occurrences, vehicles ahead, vehicles coming from opposite lanes and other warnings. The NRF module is used to establish wireless Radio Frequency (RF) communication between vehicles. The NRF modules present in both vehicles communicate with each other and send the message over a wireless medium. This type of communication is much more reliable than internet or mobile-based communication. All the functions are controlled by an Arduino Uno R3 microcontroller which integrates all the sensors present. This technology prevents accidents on roads which is one of the major issues in our country causing loss of lives. The connected vehicles or the roads provide smooth traffic, tackling congestion, and in case of any human error the vehicle can communicate with the other vehicle in a quick and wireless medium cautioning the other driver thereby avoiding fatalities.

3. Design and Development

3.1 Block Diagram and Description

The primary driving force behind this concept is the increasing number of traffic accidents. In our proposed method, we'll use NRF modules that can establish V2V communication by employing radio frequency to connect with one another (Vehicle to Vehicle Communication). It consists of modules that detect the vehicles moving beside it and communicate with them to ensure safe transit on roads to reduce the accident rate. The Arduino Nano R3 microcontroller is the heart of the system which is based on the Arduino microcontroller architecture. It will interface with all other sensors and modules. The microcontroller receives the information from all the sensors and modules and processes the data for further actuation. The most important module is the RF24L01 module which establishes the connection between the two vehicles. So, when the first vehicle detects a vehicle or experiences any sudden speed change it sends the signal to Arduino Nano which triggers the RF module to communicate this information to the other RF module present in the other vehicle. The Block diagram has two section, section one is of transmitter section. In section one, the components used for transmitting signals and sensors whose information has to be send are connected. The main component of this section is nRF module which is used to continuously transmitting the signal in the range. It uses radio frequency to communicate. The GPS sensor is used to track the vehicle. It has Hall Effect Sensor which uses magnetic waves to detect speed of vehicle and alert another vehicle if it gets overspeed. This section has Pressure Sensor which is used to detect pressure of brake if the sufficient pressure is not generated then it alerts the vehicles which are in range of it. The Accelerometer is used in this section which has capacity to measure x, y and z parameter of vehicle, in which x and y parameter is used to measure distance between two vehicle and z parameter is used to measure the slant of the vehicle and display is used to display the information coming from another vehicle.

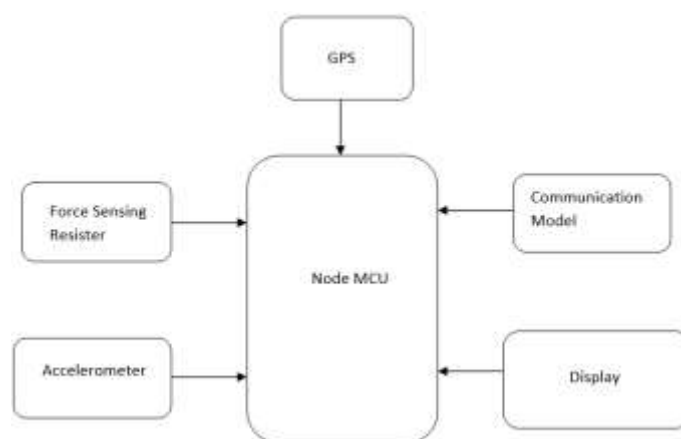

Fig. 1 – Transmitter section

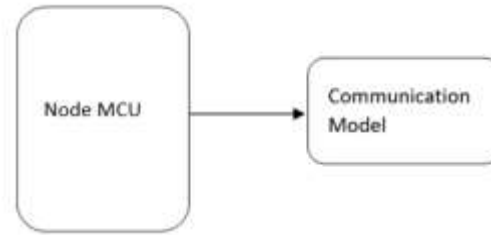

Fig. 2 – Receiver section

3.2 Methodology

The graphic below depicts the generalized block diagram of V2V communication. Two blocks are present and go to cars 1 and 2, respectively. The following is a description of these blocks. The On-Board Unit (OBU) of every vehicle will get information from GPS regarding steering angle, vehicle dimensions, speed, location coordinates, and path of the vehicle. The OBU will process the data from the GPS and, based on the data, safety alerts are generated in the board. Depending on where the vehicles are, it will produce the safety messages. The RF module will be used to send and receive the safety messages. The display unit will show simple safety instructions. The NRF module receives the information that there is a vehicle ahead and is not advisable to overtake, thereby alerting the driver which removes the risk of accident. This kind of technology will enable soft traffic movement and downgrade the accident rates which will avoid the loss of lives. Moreover, the prototype has ability to detect emergency situation. After sensing the emergency situation, the alert system generates alert for an ambulance. The alert message should contain GPS coordinates of the accident location. Here, we used GPS module to send this message. Based on the authorization of the alert message, the receiver may transmit an alert message to the nearby emergency services like a police station, ambulance etc.

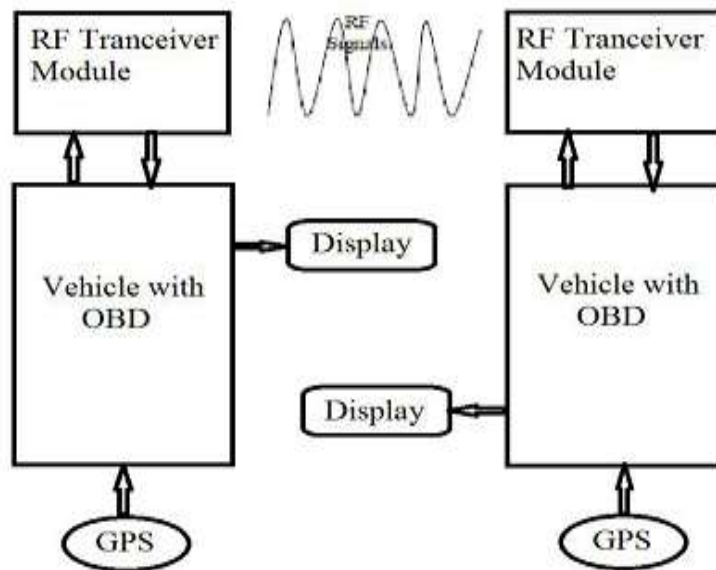

Fig. 3 – V2V Communication

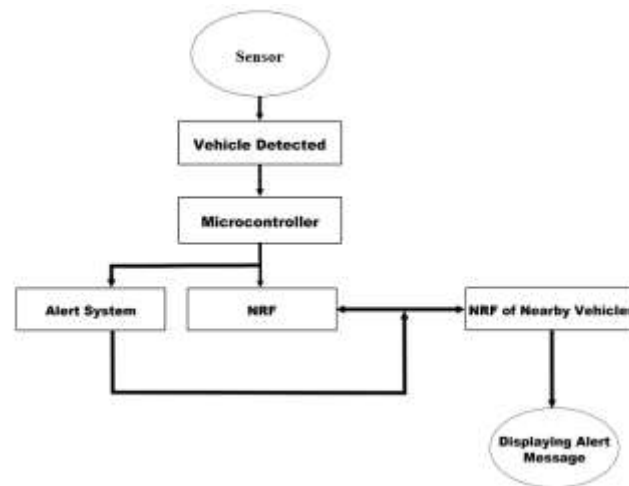

Fig. 4 – Flowchart

Advantages and Applications

4.1 Advantages

- Improving traffic management
- Providing driver assistance.
- Prevents possible crashes.
- Direction and route optimization.

4.2 Applications

- Information on traffic in real time.
- On highways, automobile will monitor and change their position.
- Warn driver if they are drifting out of their lane.
- If they get too near to the car in front of them, they will slow down.
- Anti – theft
- Live Tracking
- Over speed Notification

5. Conclusion and References

5.1 Conclusion

The development of a vehicular communication system using RF technology with a mesh network is an exciting area of research that has the potential to revolutionize the way we drive. The proposed system is expected to improve road safety, reduce traffic congestion, and enhance the overall driving experience. The system can also be used to collect data about traffic patterns, which can be used to optimize traffic management strategies. The future of vehicular communication systems looks promising, and we can expect to see more advancements in this area in the coming years. We have analyzed situations like collision, delay and redundancy etc. which can be improved or overcome with simple warning message transmission. GPS is used so that V2V system processor can identify the speed, direction and location of the other vehicle. More sensors can be included for better working and accuracy. Future cars will be more intelligent which can make its own decision for the safety purpose. Quick help will be provided by knowing the location if the advance system also embedded in ambulance.

References

- [1] U.S. Department of Transportation, this publication is distributed by the U.S Department of Transportation, National Highway Traffic Safety Administration.
- [2] Mr. Anthonylan Smith, Penn State Harrisburg, Pennsylvania State University published a paper.
- [3]"Vehicular communication system using RF technology with mesh network", S. Guo, Y. Wu, and X. Li, IEEE Access, vol. 7, pp. 123623-123633, 2019.
- [4] "A review of research on vehicular communication systems using mesh networks", X. Liu, Q. Li, and Y. Zhang, Wireless Communications and Mobile Computing, vol. 17, no. 15, pp. 2217-2233, 2017
- [5] "Vehicular communication system using RF technology with mesh network for traffic management", D. Zhang, X. Wang, and Z. Liu, Journal of Intelligent Transportation Systems, vol. 22, no. 6, pp. 443-452, 2018.
- [6] "A novel vehicle-to-vehicle communication system based on mesh network", C. Wang, J. Wang, and Y. Wang, Journal of Electronics and Information Technology, vol. 39, no. 2, pp. 404-410, 2017.
- [7] "Performance analysis of vehicular communication system using RF technology with mesh network", S. S. Islam, S. Islam, and M. F. Hossain, Proceedings of the 2018 4th International Conference on Computer and Information Sciences, pp. 1-6, 2018.
- [8] "Vehicle Position and Context Detection Using V2V Communication", Paul Watta, Member, IEEE, Ximu Zhang, Student Member, IEEE, Yi Lu Murphey, Fellow, IEEE, 2020
- [9] "Advantages in Crash Severity Prediction Using Vehicle to Vehicle Communication", Dennis Bohmlander, Sinan Hasirlioglu, Vitor Yano, Christian Lauerer, Thomas Brandmeier and Alessandro Zimmer,2015
- [10] "Vehicle to Vehicle Communication for Crash Avoidance System", N. G. Ghatwai, Prof. V. K. Harpale, Dr. Mangesh Kale,2016
- [11] "Use of Mobile Mesh Networks for Inter-Vehicular Communication", Dr. Paul Beckman Dr. Sameer Verma, Dr. Ramesh Rao,2003
- [12] "Vehicular Communication Establishment using NRF with Emergency Alert System", R. Prithvik Adithya I, Naren Subra M. V., Somya Gupta,2020