



## **D-Statcom for Power Quality Improvement in Distribution Power System using Matlab Simulink**

*Naga Gayatri<sup>a</sup>, M. Sekhara<sup>b</sup>*

<sup>a</sup> M. Tech, Student Electrical Power System, CRIT College Anantapur, Andhra Pradesh, India

<sup>b</sup> M. Tech, Student Electrical Power System, CRIT College Anantapur, Andhra Pradesh, India

---

### **ABSTRACT**

In today's scenario Power Quality issues are turned into a serious matter for both electric power utilities and the power system engineers. Dynamic loads are one of the major causes of power quality debasement in power transmission lines. Due to their high nonlinearity and timevarying behavior, various power quality issues like voltage variation, harmonic distortion arises in the system. Simulation of the system will be carried out using MATLAB/SIMULINK software to obtain the result. When there is an overload in the system, high current will flow through the line and the consequence voltage sag will occur. In order to improve voltage sag, D-STATCOM will connect to the system. In this project, the performance of D-STATCOM both before and after saging will be analyzed.

**Keywords:** Analyzed

---

### **INTRODUCTION**

In today's society demands for power have increased. A Modern power system is more complex and it is required to fulfill the demand with better power quality. The construction of new transmission lines and power stations increases the problem of system operation as well as the overall cost. Normally, Poor power quality is caused by power line disturbances such as impulses, voltage sag and swell, voltage and current unbalances, momentary interruption and harmonic distortions. The other major causes of poor power quality are harmonics and reactive power. The solid state control of ac power using high speed switches are the main cause of harmonics whereas dynamic loads contribute to excessive drawn of reactive power from supply. Reactive power causes an increase in the transmission losses, a decrease in power quality and the changes in the voltage amplitude at the end of the lines. Nowadays advanced technologies are being used for improving power system reliability, security, and profitability. To achieve optimum performance of the power system it is essential to control reactive power flow in the network. Reactive power flow can be controlled by using FACTS devices like distribution static compensator (DSTATCOM), Static VAR Compensator (SVC), Unified powerquality conditioner (UPQC), etc. The Flexible AC Transmission System devices (FACTS) offer a fast and reliable control over the transmission parameters, i.e. Voltage, line impedance, and phase angle between the sending and receiving end voltage [3]. On the other hand, the custom power is for low voltage distribution, and improving the poor quality and reliability of supply affecting sensitive loads. The most widely known custom power devices are UPQC, D-STATCOM, DVR among them D-STATCOM can provide cost effective solution for the compensation of reactive power and unbalance loading in distribution system[4]. D-STATCOM can be used to provide voltage regulation, power factor correction, compensation of harmonics and during transient condition provides leading or lagging reactive power to active system stability. It can exchange both active and reactive power in distribution system by changing the amplitude and phase angle of the converter with respect to the terminal voltage of the line.

---

### **LITERATURE SURVEY**

In power system networks generation of harmonics and the of waveform pollution are important problems the power utilities facing. Serious power quality problems can be caused by distorted currents from those nonlinear loads due to the widespread proliferation of many nonlinear harmonic loads by various power electronic-based equipment on a consumer side. In addition, the increase in nonlinear loads might even distort the grid voltage. As a result, a distributed power system can be placed in an undesired situation by these power quality problems. For example, it is known that a power outage may occur as a result of serious voltage distortion. To tackle these

problems, the limits on the amount of harmonic currents and voltages generated by customers and/or utilities have been established in IEEE Standard 519 and IEC-61000-3 Standard. However, these limits are based on conventional power quality indexes (PQIs), such as total harmonic distortion (THD), which determines how much the waveform is distorted with high-frequency harmonic components. The THD regulates the harmonic pollution of each load. However, it is insufficient for analyzing the effects of polluted loads on an overall power system with the only THD factor. Therefore, a new PQI is necessary to deal with this issue. In addition, measurement methods and several PQIs have been reported with the analysis of distorted voltage and

current waveforms. However no research has investigated the use of the PQI, which focuses on the direct relationship between distortion power and harmonic problem. This project introduces the new PQI to monitor the effect of each nonlinear load on a point of common coupling (PCC) of a distribution power system by using the concept of distortion power generated from each load.

---

## **PROBLEM FORMULATION**

This project proposes Dynamic loads are one of the major causes of power quality debasement in power transmission lines. Due to their high nonlinearity and timevarying behavior, various power quality issues like voltage variation, harmonic distortion arises in the system. Poor power quality is caused by power line disturbances such as impulses, voltage sag and swell, voltage and current unbalances, momentary interruption and harmonic distortions .The other major causes of poor power quality are harmonics and reactive power. The solid state control of ac power using high speed switches are the main cause of harmonics whereas dynamic loads contribute to excessive drawn of reactive power from supply. Reactive power causes an increase in the transmission losses, a decrease in power quality and the changes in the voltage amplitude at the end of the lines. Nowadays advanced technologies are being used for improving power system reliability, security, and profitability.

### ***OBJECTIVE OF THESIS***

Dynamic loads are one of the major causes of power quality debasement in power transmission lines. Due to their high nonlinearity and time varying behavior, various power quality issues like voltage variation, harmonic distortion arises in the system. Simulation of the system will be carried out using MATLAB/SIMULINK software to obtain the result. When there is an

overload in the system, high current will flow through the line and the consequence voltage sag will occur. In order to improve voltage sag, D-STATCOM will connect to the system

### ***ORGANIZATION OF THE THESIS***

Chapter 1 describes the introduction to the project. Chapter 2 describes the introduction to power quality and power quality issues. Chapter 3 covers the converter circuits in power electronics. Chapter 4 covers the FACTS devices. In chapter 5 we will discuss detailed about the STATCOM. Chapter 6 describes about matlab Simulink. Chapter 7 we will discuss about the simulation results. Chapter 8 deals with conclusion. The later section covers the references for this document.

---

## **POWER QUALITY**

### **1. POWER QUALITY**

Conceivably, the best electrical supply would be a steady greatness and frequency sinusoidal voltage waveform. On account of the non-zero impedance of the supply framework, of the expansive assortment of loads that may be experienced and of other phenomena, for example, transients and outages, the truth is regularly diverse. The Power Quality of a system communicates to which degree a practical supply system looks like the perfect supply system.

If the Power Quality of the system is good, then any loads associated with it will run satisfactory and efficiently. Establishment running expenses and carbon footprint impression will be insignificant.

If the Power Quality of the system is awful, then loads joined with it will fail or will have a decreased lifetime, and the efficiency of the electrical establishment will diminish. Establishment running expenses and carbon footprint impression will be high and/or operation may not be conceivable at all cost of poor power quality.

Poor Power Quality can be depicted as any occasion identified with the electrical system network that ultimately results in a budgetary misfortune. Conceivable results of poor Power Quality incorporate

- Unexpected power supply failures (breakers tripping, wires blowing).
- Equipment failure or failing
- Equipment overheating (transformers, engines) are prompting their lifetime reduction.
- Damage to delicate supplies (Pe's, production line control frameworks).
- Electronic communication interferences
- Increase of system power losses

Generation of the existence of waveform pollution and harmonics in power system networks are important problems facing the power utilities. Serious power quality problems can be caused by distorted currents from those nonlinear loads due to the widespread proliferation of many nonlinear harmonic loads by various power electronic-based equipment on a consumer side. In addition, the increase in nonlinear loads might even distort the grid voltage.

As a result, a distributed power system can be placed in an undesired situation by these power quality problems. For example, it is known that a power outage may occur as a result of serious voltage distortion. To tackle these problems, the limits on the amount of harmonic currents and voltages generated by customers and/or utilities have been established in IEEE Standard 519 and IEC-61000-3 Standard. However, these limits are based on conventional power quality indexes (PQIs), such as total harmonic distortion (THD), which determines how much the waveform is distorted with high-frequency harmonic components. The THD regulates the harmonic pollution of each load. However, it is insufficient for analyzing the effects of polluted loads on an overall power system with the only THD factor.

### ***DEFINITION OF POWER QUALITY***

Power quality could be a term which means various things to completely different individuals. Institute of Electrical and Electronic Engineers (IEEE) normal IEEE1100 defines power quality as “the conception of powering and grounding sensitive instrumentation equipment in an exceedingly manner appropriate for the equipment. All electrical devices are prone to malfunction or failure when exposed to more power quality problems. The electrical machine be a transformer, an electric motor, a computer a generator, a printer, a household appliance, or a communication equipment. Depending on the severity of problems others and all of these devices react adversely to power quality issues.

### ***POWER QUALITY PROGRESSION***

Since the invention of power 300 years ago, the distribution, generation and use of electricity have correctly evolved. New and innovative suggest to generate and use electricity the economic revolution, and since then engineers, scientists, and hobbyists have contributed to its continued evolution. In the starting stage, electrical devices and machines were crude at best but nonetheless more utilitarian. They performed quite well and consumed gain amounts of electricity. The machines were designed with price consideration solely secondary to performance issues. They were probably liable to however the consequences were not readily discernible, whatever power quality problems existed at the time, and due partly to the robustness of the machines and due to the lack of good ways to measure parameters of power quality. However, within the last 50 years or so, the economic years to the need for products which are to be economically competitive, that meant that electrical machines were smaller and more efficient and were designed without performance margins. At a uniformity time, diverse variables were becoming possibly the most important factor.

The difficulty in quantifying power quality considerations is explained by the character of the interaction between susceptible equipment and power quality. What is bad power for one piece of instrument might be good power for another one. Because of differences in their component tolerance and manufacturing or two identical pieces or devices of equipment might react differently to the actual power quality parameters attributes to variations

### ***POWER QUALITY NOMENCLATURE***

Webster’s New World Dictionary defines nomenclature as the “the terms employed in a specific art science etc.” Understanding the terms employed in any branch of humanities or science is basic to developing a way of familiarity with the topic. The science of power quality is not any exception. Most commonly used power quality terms are explained and outlined below:

**Bonding:** Inter connecting the conductive parts electrically to ensure common voltage between the connected parts. Electrical bonding is done for two reasons. When bonded using low impedance connections, conductive parts, would be at the same electrical potential, which means that the difference in voltage between the connected parts would be negligible or minimal. Electrical Bonding additionally states current likely imposed on a metal part should be safely conducted to other grid systems or ground serving as ground.

**Capacitance:** It is the Property of a circuit element .it is characterized by an insulating medium which contains two conductive parts. The capacitance unit is Farad (F), named for the scientist Michael Faraday. Capacitance values are commonly expressed in microfarad (F), which is  $10^{-6}$  of a Farad. The Capacitance by means which electrical energy or electrical noise can couple from one electrical circuit to another. Between two conductive parts Capacitance can be made infinitesimally small but may not be eliminated completely.

**Coupling:** The Process by which electrical noise or energy in one circuit will be transferred to another circuit that may be electrically connected to it.

**Crest factor:** It is the Ratio of the peak value of a periodic wave form and the root mean square (RMS) value of a periodic waveform is called crest factor. From its ideal characteristics, Crest factor is the indications of the distortion in a periodic waveform.

**Distortion:** The variation of a periodic wave from its ideal waveform characteristics is called distortion. The distortion which is introduced in a wave will create waveform phase shift as well as deformity

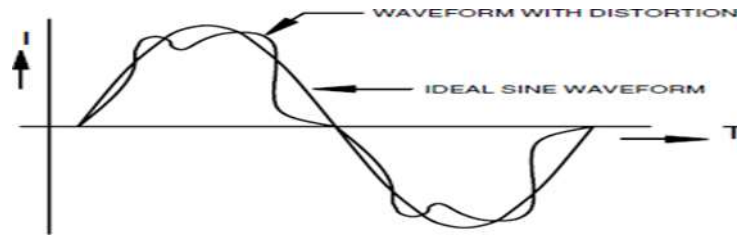

Fig. 2.1 Distortion

**Distortion factor:** The percentage expressed as a Ratio between the RMS of the periodic wave consist of a harmonic content to the RMS of the fundamental content of the wave. This is also called as the Total Harmonic Distortion (THD).

**Flicker:** To allow the visual observation of a change in electric light source intensity variation of input voltage sufficient in duration. The flicker can be expressed as the change in voltage over nominal voltage.

**Form factor:** Form factor can be defined as the ratio between the RMS value and average value of the periodic waveform. Form factor is another indicator of the deviation of a periodic waveform from the ideal characteristics. For example, The RMS value of the sinusoidal wave is 0.707 times the peak value, the average value of a pure sinusoidal wave averaged over a cycle is 0.637 times the peak value. The form factor, is calculated as

$$\text{Form Factor} = 0.707/0.637 = 1.11.$$

**Frequency:** Number of cycles per second is called frequency. The frequency of the electrical parameters such as voltage and current is expressed in hertz (Hz).

**Ground electrode:** To provide a connection with the ground, Conductor or a body of conductors in intimate contact with earth.

**Ground grid:** System of interconnected bare conductors buried below the surface of the earth and arranged over a specified area in a specified pattern.

**Ground loop:** If two points in an electrical system which are nominally at ground potential will be connected by a conducting path such that both or either points are not at the same ground potential, potentially detrimental loop formed.

**Ground ring:** Ring encircling the structure or building which is directly contact with the earth. This ring will be at a depth below the surface of the earth which not less than 2.5 ft and it also consist of at least 21 ft of empty copper conductor which is not smaller than #2 AWG.

**Grounding:** Conducting connection by which an equipment or electrical circuit is which connected to the earth or some conducting part of relatively high extent which serves in place of the earth. The metallic noncurrent carrying parts of equipment grounding is done primarily for safety reasons. In the case of a fault between the frame and an energized conductor, the metal frame of equipment grounding protects anyone entering into contact with the equipment frame from electrical shock. Grounding the equipment frame also ensures that plane ground a protective device or prompt passage of fault current to the ground electrode would separate the faulty equipment from the electrical power supply clear the fault and operated to clear the faults.

**Harmonic distortion:** The distortion from a pure sinusoidal waveform.

**Harmonic:** A periodic wave of Sinusoidal component which is having a frequency which is an integral multiple of the fundamental frequency. So if the fundamental frequency is 60 Hz, then the third harmonic is a sinusoidal wave of 180 Hz, the sixth harmonic is a sinusoidal wave of 360 Hz, and so on.

**Impulse:** Normally Impulse used to indicate a short duration overvoltage occurs with certain fall and raise characteristics. The Standards have affected including the term impulse in the category of transients.

**Inductance:** Inductance is that the relationship between the magnetic lines of flux ( $\Phi$ ) which links a circuit due to the current (I) producing the flux. If I will be the current in a wire which produces a magnetic flux of  $\Phi$  lines, so the self inductance of the wire, L, is equal to  $\Phi/I$ . The Mutual inductance (M) is relationship between the magnetic flux  $\Phi_2$  linking an adjacent circuit 2 due to current I1 in circuit 1. This can be stated as  $M = \Phi_2/I_1$ .

**Inrush:** when a machine is initially turned on, the large current that a load draws are called inrush currents.

**SIMULATION RESULTS**

**WITHOUT INSERTION OF D-STATCOM**

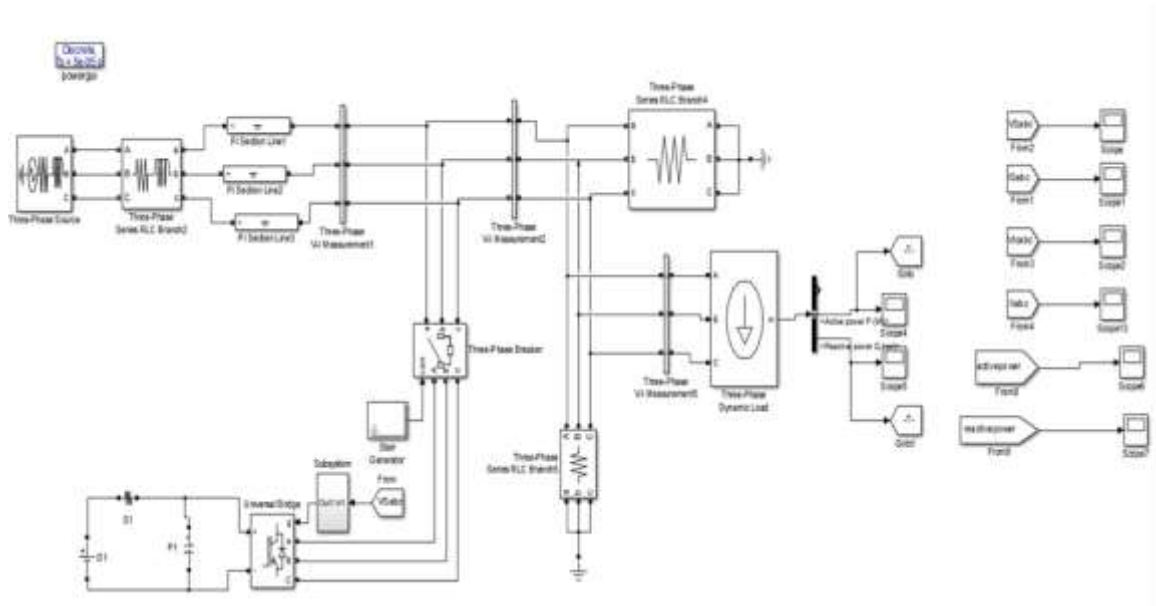

Fig. 7.1 simulink diagram without insertion of D-STATCOM

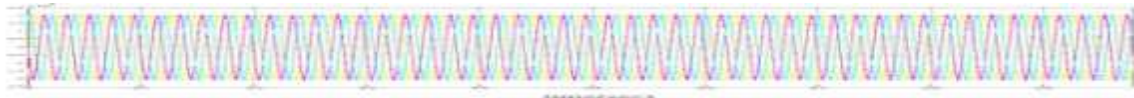

Fig. 7.2 supply voltage without compensation

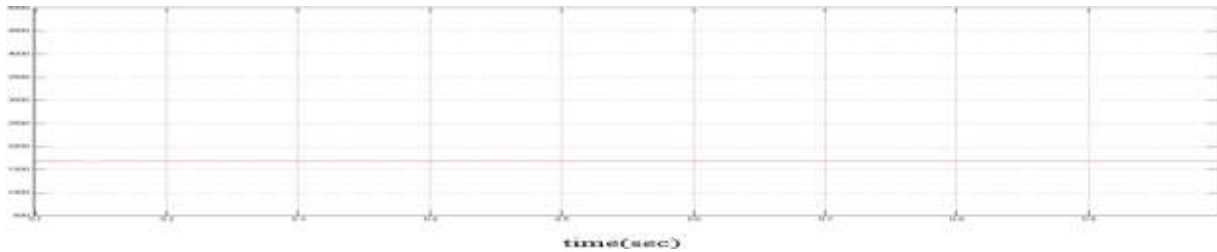

Fig. 7.5 Reactive power of load side



Fig. 7.8 THD diagrams before compensation

**SIMULINK RESULT WITH D-STATCOM**

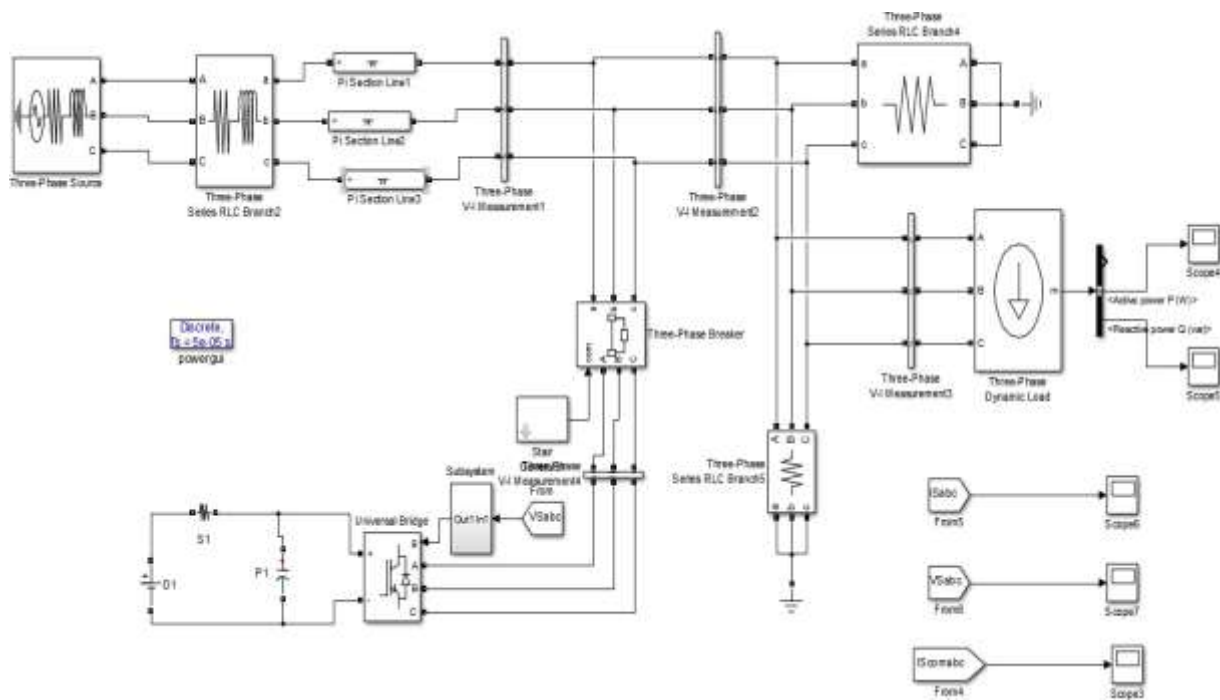

Fig. 7.9 simulink diagram with insertion of D-STATCOM

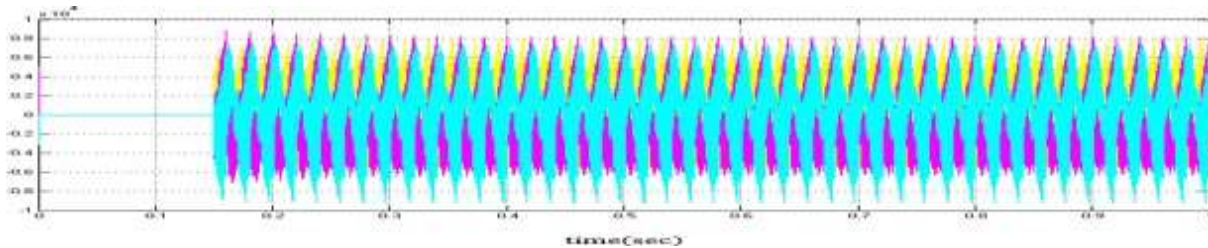
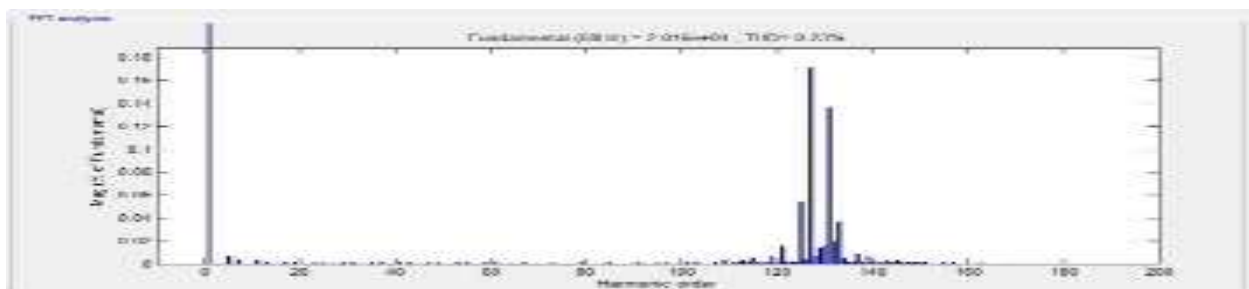

Fig. 7.12 compensating current from D-STATCOM



THD diagram after compensation

**CONCLUSION**

Power quality is the major criteria in distribution system. Power quality is improved by injecting compensating current at the load side to utilize the real power maximum by the system. In this project, modeling and analyzing of the power system is being integrated with D-STATCOM at distribution grid, at the consumer end. D-STATCOM is employed to reduce the harmonics and to compensate reactive power. Without D-STATCOM source current THD is 50.79% and then with D- STATCOM, THD has been reduced to 0.23%.

Before compensation, the unbalanced dynamic load injects harmonic currents to the source side and affects the source, due to which the waveform of source current becomes distorted. This can be overcome by using D-STATCOM by connecting as shunt at the distribution side by means of a tie reactance connected to compensate the load current. It can be concluded that D-STATCOM is an effective device for PQ improvement in the distribution system.

#### REFERENCES

- [1]. A.Bhattacharya and C. Chakraborty, "A shunt active power filter with enhanced performance using ANN-based predictive and adaptive controllers," *IEEE Trans. Ind. Electron.*, vol. 58, no. 2, pp. 421–428, Feb. 2011.
- [2]. S. Rahmani, A. Hamadi, and K. Al-Haddad, "A Lyapunov-function-based control for a three-phase shunt hybrid active filter," *IEEE Trans. Ind. Electron.*, vol. 59, no. 3, pp. 1418–1429, Mar. 2012.
- [3]. M. K. Mishra and K. Karthikeyan, "An investigation on design and switching dynamics of a voltage source inverter to compensate unbalanced and nonlinear loads," *IEEE Trans. Ind. Electron.*, vol. 56, no. 8, pp. 2802–2810, Aug. 2009.
- [4]. J. Liu, P. Zanchetta, M. Degano, and E. Lavopa, "Control design and implementation for high performance shunt active filters in aircraft power grids," *IEEE Trans. Ind. Electron.*, vol. 59, no. 9, pp. 3604–3613, Sep. 2012.
- [5]. A.Bhattacharya, C. Chakraborty, and S. Bhattacharya, "Parallelconnected shunt hybrid active power filters operating at different switching frequencies for improved performance," *IEEE Trans. Ind. Electron.*, vol. 59, no. 11, pp. 4007–4019, Nov. 2012.
- [6]. Q.-N. Trinh and H.-H. Lee, "An advanced current control strategy for three-phase shunt active power filters," *IEEE Trans. Ind. Electron.*, vol. 60, no. 12, pp. 5400–5410, Dec. 2013.
- [7]. M. K. Mishra, A. Ghosh, and A. Joshi, "Operation of a DSTATCOM in voltage control mode," *IEEE Trans. Power Del.*, vol. 18, no. 1, pp. 258–264, Jan. 2003.
- [8]. H. Fujita and H. Akagi, "Voltage-regulation performance of a shunt active filter intended for installation on a power distribution system," *IEEE Trans. Power Electron.*, vol. 22, no. 3, pp. 1046–1053, May 2007.
- [9]. R. Gupta, A. Ghosh, and A. Joshi, "Performance comparison of VSCbased shunt and series compensators used for load voltage control in