



Smart Drainage System Using IOT

Kamal Sahoo¹, Janhvi Tambe², Shravani Patil³, Abhishek Mathpati⁴, Mrs. Prachi Kalpande⁵

^{1,2,3,4,5}Student, Information Technology Pravin Patil Polytechnic

⁵Senior Lecturer, (ME in electronics and communication) Information Technology, Pravin Patil Polytechnic

ABSTRACT:

This project aims to address the challenges of human-driven well maintenance, which can be environmentally burdensome and logistically difficult. Instead, the project focuses on developing an intelligent drainage system using Internet of Things (IoT) technology. In this system, sensors are placed in wells to monitor water levels, sediment accumulation and other important factors. The data collected by these sensors is transmitted to the administrative center of the city government through an Android application. This allows for a quick response to potential problems and puts public safety first. By implementing IoT sensors, the system ensures continuous monitoring of drainage parameters and provides valuable real-time information. By integrating data analysis and intelligent controls, it optimizes the performance of sewer networks, reduces maintenance costs and improves flood control measures. Ultimately, this project aims to create a resilient and sustainable urban environment while demonstrating the transformative potential of IoT in urban infrastructure.

Keywords- Iot, Manholes, sensors.

1. INTRODUCTION:

The Internet of Things (IoT) is a concept that focuses on connecting physical objects to communication devices, which in turn are connected to networks of sensors. This connectivity enables seamless communication and automated interaction between the physical world and the digital realm. Before the Internet of Things, computers could independently access data from objects and devices, but the Internet of Things was developed to overcome the limitations associated with manual data entry. It aims to improve the efficiency, accuracy and overall usefulness of data collection and management. Sensor networks are an important part of how the Internet of Things works and are essential to its successful implementation. Simply put, IoT means connecting everyday objects to the Internet using sensors and communication devices so that they can automatically collect and share data.

This information can then be used for various purposes, such as increasing efficiency and making better decisions in areas such as healthcare, agriculture, transportation and more. Sensor networks are like the "eyes and ears" of the Internet of Things, helping it gather information from the physical world. The drainage system is an important part of large cities with millions of inhabitants.

This is the basis for keeping the land dry by managing excess and sewage, including rainwater and sewage. Monitoring the condition of the sewage system is essential to ensure it is working properly. Unfortunately, not all regions have dedicated drainage monitoring teams, which leads to inconsistent monitoring of drainage conditions.

This irregular monitoring contributes to clogging of drainage systems, which leads to localized flooding. Manual monitoring methods also prove ineffective and insufficient. An inefficient and improper sewage system poses significant risks in terms of water and soil contamination and the spread of disease, especially in relation to climate change. Properly maintained and monitored drainage systems are essential to reduce these risks and ensure a healthy urban environment.

The problem of open manhole covers can have disastrous consequences, leading to accidental falls and loss of life. Such open wells can be for various reasons such as broken covers, well explosions caused by dangerous gases inside, or sewage overflows, which in addition to polluting the environment also spread infectious diseases. In addition, it can contaminate drinking water and cause serious health risks.

The implementation of an intelligent drainage system is crucial to solving these problems holistically. This system collects and transmits real-time data from well sensors to a central control station. The development of a smart drainage system using IoT technology is not only a response to solving urban problems, but also in line with the broader goal of creating smart, sustainable and resilient cities. This project offers an opportunity for innovation at the intersection of technology and urban infrastructure. Its potential impact extends to improving the quality of life of urban dwellers and mitigating the environmental effects of urbanization.

2. METHODOLOGY

In this system, sensors are placed inside the well, which detect and transmit the necessary information about the water level, openings and other factors to the treatment plant (Oma irtyam) using a Wi-Fi module. This allows the to take precautions to address the problem with public safety in mind.

Advance drainage system –

The current drainage system is not computerized. Therefore, when a blockage occurs, it is always difficult to find out the exact location of the blockage. Also, no early warnings about blocking are sent. Because of this, it takes time to identify and correct blockages. It is very difficult to deal with the situation when the pipes are completely blocked. People face many problems due to this type of sewage failure.

Software and Hardware Requirements -

Developing an IoT-based system has certain requirements, especially if it performs a certain task automatically.

The Software and Hardware Requirements –

Hardware Requirements:

- Node MCU
- Tilt sensor
- Load sensor

Software Requirements:

- Firebase
- Android Studio
- Arduino IDE
- Proteus 8
- Ultrasonic sensor

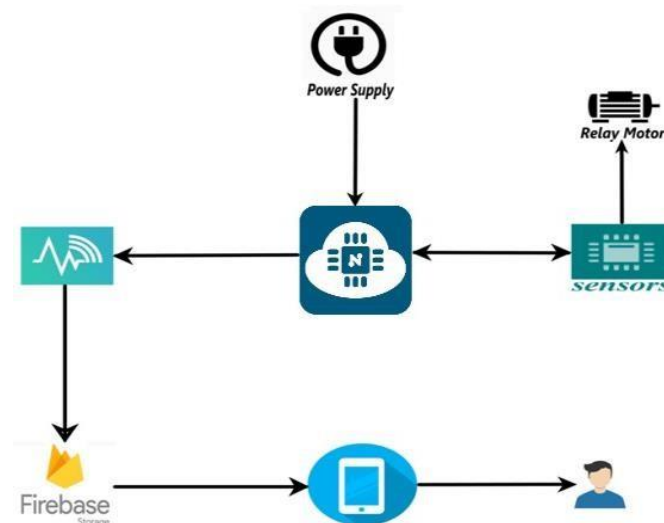

The Internet of Things:

The Internet of Things (IoT) is a revolutionary concept that combines the physical and digital dimensions. It connects everyday objects with sensors and communication devices, allowing them to collect and exchange data and operate autonomously.

IoT corrects the limits of human contribution and strives for cost-effectiveness, precision and versatility. Sensor networks are the cornerstone of the IoT paradigm, driving its transformation. The Internet of Things enables objects to intelligently interact with both the real and digital worlds, providing unprecedented automation and connectivity.

Node MCU-

The Node MCU is built on the ESP8266, a low- cost, low-power, well-integrated Wi-Fi microcontroller. The ESP8266 provides both Wi-Fi connectivity and a microcontroller, making it a suitable choice for IoT applications

**Load sensor-**

A load cell, often called a load cell, is a sensor used to measure force or weight. It transforms a mechanical force or load into an electrical signal, usually in the form of changes in voltage, current or resistance.

**Ultrasonic sensor-**

Ultrasonic sensors work on the principle that they send and receive sound waves beyond the range of human hearing. They emit high-frequency ultrasound pulses and measure the time it takes for these sound waves to bounce back after hitting an object. By detecting the speed of sound in the surrounding environment, the sensor can calculate the distance to the target.

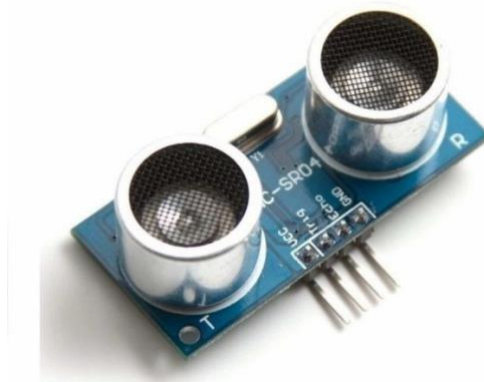
**Tilt sensor-**

Tilt sensors allow you to detect direction or tilt. They are small, cheap, consume little power and are easy to use. Their simplicity makes them popular among toys, gadgets and home appliances. This sensor is attached to the well cover. So every time the lid is moved, it sends data to the Arduino UNO microcontroller, which is then sent as an alarm/notification to the management station.

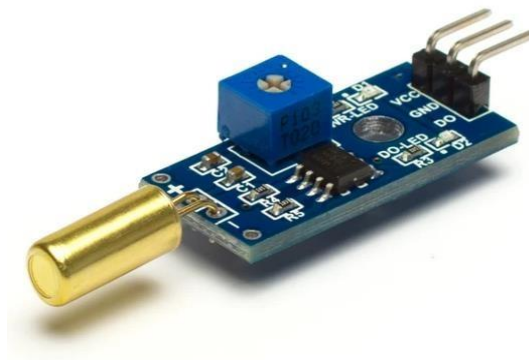

3. LITERATURE REVIEW

In 2014, Mr. Muragesh SK. proposed an underground sewer and well monitoring system using the Internet of Things (IoT). The important aspects of this design are low cost, low maintenance, fast deployment and a large number of sensors, long service life and high service quality.

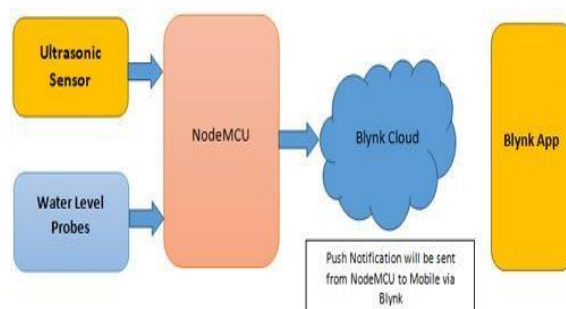

Sewer maintenance is essential to keeping a city clean, safe and healthy. If sewage is not adequate, clean water becomes contaminated with sewage and infectious diseases can spread. To solve these problems, most cities have adopted an underground drainage system. When the drain is blocked, many problems occur, such as traffic jams, environmental pollution, and if the drain cover is not properly closed, there is a risk of accidents and the well falls into the well. Human-led maintenance of wells is very difficult because the environment is bad and it is difficult to enter the wells to check the condition of the wells. To solve all these problems, it is necessary to implement a remote monitoring and signaling system, which sends the information detected by the sensors placed in the service opening to the gas station of the current state. Various types of sensors such as weight sensor (load sensor), flow sensor, water sensor, buzzer, water level sensor etc. when placed in the well, these sensors detect any problems like water blockage or debris accumulation or water flow stoppage. . etc. and immediately an alarm is sent to the administrative point about the problem ie. Municipal Corporation.

If there is a problem in the corridor, the venerable sensor detects it and then triggers the circuit to which the sensor is connected. Since the data (signal) is in electronic form, there is a device connected to the circuit that transforms the electronic data (signal) sent from the sensor to the circuit into serial data. Then the serial data received from the serial port is displayed in the terminal ie. City Corporation Screen (Control Station).

In 2020, G. Durvasi, G. Keerthi, V. Phani Sonika, T. Hepsiba Susan proposed a system called Smart Drainage Management System. The Internet of Things (IoT) describes physical objects embedded with sensors, processing capabilities, software and other technologies to connect and exchange data with other devices and systems via the Internet or other communication networks. Sewage overflow on the roads was also a big problem in many developed and underdeveloped cities. The existing drainage system is manual and there are insufficient monitoring teams in all areas. Manual inspection is relatively difficult. It requires a lot of manpower that wants to save only limited reports in low resolution. The above article provides design information based on IoT applications. This project represents the implementation of monitoring and control of underground systems using different approaches.

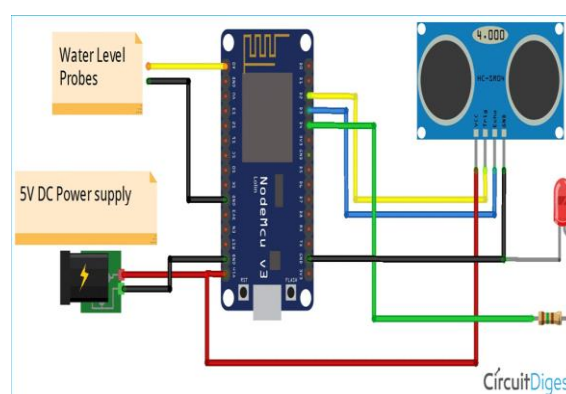

It describes the water flow system by giving the water flow and detecting overflow. It also uses an observational method to detect faults in sewer pipe blocks based on water flow. A smart drainage system has sensors that detect blockages and floods. The Node MCU Wi-Fi module is the user interface of the Wi-Fi organization to import or transfer data to the network. The center of the Wi-Fi module sends this information in its entirety to the database.

ADVANTAGES

1. Factors that can open the well are clearly known by the sensors.
2. Unwanted problems can be solved by detecting and changing the opening of the borehole to the relevant authorities.
3. Detecting a well opening or overflow as soon as possible prevents the spread of infectious diseases.

4. Keeps cities clean

APPLICATIONS

Health: -

- a. Discovery and monitoring of the well opening prevents the spread of infectious diseases.
- b. Prevents contamination of clean water. Disaster Management: -
 - a. Warns and prevents sewage overflows, which cause problems in everyday life and the surrounding environment.

Social: -

- a. It keeps cities clean.
- b. Prevents loss of life.

References

1. Muragesh SK, Santhosha Rao, "Internet of Things Automatic Monitoring System for Underground Sewers and Wells in Metropolis". International Journal of Information and Computing Technology. ISSN 0974-2239, osa 4, numero 12 (2014), s. 1211-1220
2. Tushar Pathak¹, Sanyogita Deshmukh², Pooja Reddy³, prof H. P. Rewatkar⁴, Smart Drainage Monitoring and Controlling System using IOT" International Journal of Research in Engineering and Science (IJRES) ISSN (Enreta): 2320-9364, ISSN (tulostus): 2320-9356

Bibliography

1. D P Kothari, I J Nagarth "Peruselectronics", McGraw Hill Education.
2. Charles K. Alexander, Matthew N.O. Sadiku "Fundamentoj de Elektraĵ Cirkvitoj" seitsemäspainos, McGraw Hill Education.
3. Vijaya V Pangave, K P Akole, Munjushri Joshi, "Digital Techniques", Nirali Prakashan
4. James Arthur "Aduino".
5. Dr. Sanjay Sharma, "Analog Integrated Electronics", Katson Books.
6. Hanuman Yadav, first step