



Latest Advancements in Electric Vehicles

Arhant Tewari, Aniket Jha, Hammad, Dr. JP Kesari

Delhi Technological University

ABSTRACT

This paper provides an overview of the latest work of electric vehicles in the world. The paper outlines the development, evolution, and the comparison of various different parts of components involved in the design and manufacturing of EVs. The major components involved include battery technology, charger design, motor, steering, etc. The paper at length highlights some electric vehicle prototype as a conclusion to the paper.

Keywords – Electric vehicle, AF, steering system, braking system, ABS, battery management systems, BMS, Inverter

1. INTRODUCTION

Electrical vehicles (EVs) are based on electric propulsion systems, no internal combustion (IC) engine is used. All the power is rooted on electric power as the primary energy source. The main advantage is the high efficiency of power conversion through its proposition system of the electric motor. Recently there has been great research and developmental work reported in both academia and industry. Commercial vehicles are also available, and many countries have already provided various motives to users and manufacturers by lowering lower tax or providing tax exemption, free parking, and subsidized charging facilities. On the other hand, the hybrid electric vehicle (HEV) is another possible alternative. It has been used widely in the past few years. Nowadays, almost all the car manufacturers have at least one model in hybrid electric vehicle. The questions that arise here is: Which vehicle will dominate the market, and is suitable for future? This paper is to examine the recent development of electric vehicle and suggest the future development in this regard.

EV, SERIES AND PARALLEL HYBRIDS

HEV has been fostered extensively in the last decennary. It is meant to rescue the battery energy storage problems at that time. Using hybrid vehicles allows electric power to be acquired from engine. HEVs are classified into two categories: series hybrid and parallel hybrid. The engine power of the series hybrid completely depends on the battery as, all the motor power is derived from the battery. As for the parallel hybrid, both the engine and motor contribute to the total propulsion power output. The torque derived is the net sum of both the motor and engine. Also note that, motor can also be used as a generator to absorb the power from engine through the battery transmission. Both series and parallel hybrids can absorb power through regeneration during braking or deceleration.

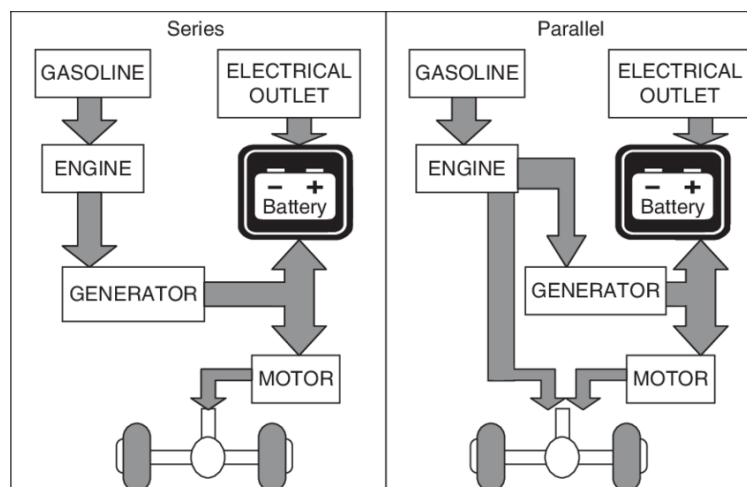

Figure 1 Series or Parallel path of an EV

Nonetheless, HEV still has emission issues which needs to be taken care of. The latest developments in the field of plug-in HEV attempts to solve some of these problems. It accepts electric power to battery via plug in from the mains. Therefore, when convenient, users may charge the battery using AC from the mains.

KEY COMPONENTS IN EV

The electric vehicle has a rather straightforward structure. The key components are the propulsion parts shown in detail in Fig 2, the battery is the main energy storage, battery chargers are used to convert the electricity directly from mains to charge the battery. The battery voltage is DC, and it is reversed into switched-mode signal through power electronic inverter to drive the motor. The other electronic components in a vehicle can be supplied to the battery through AC-DC converter that step downs the voltage from the battery pack to voltages as low as 20-50 V.

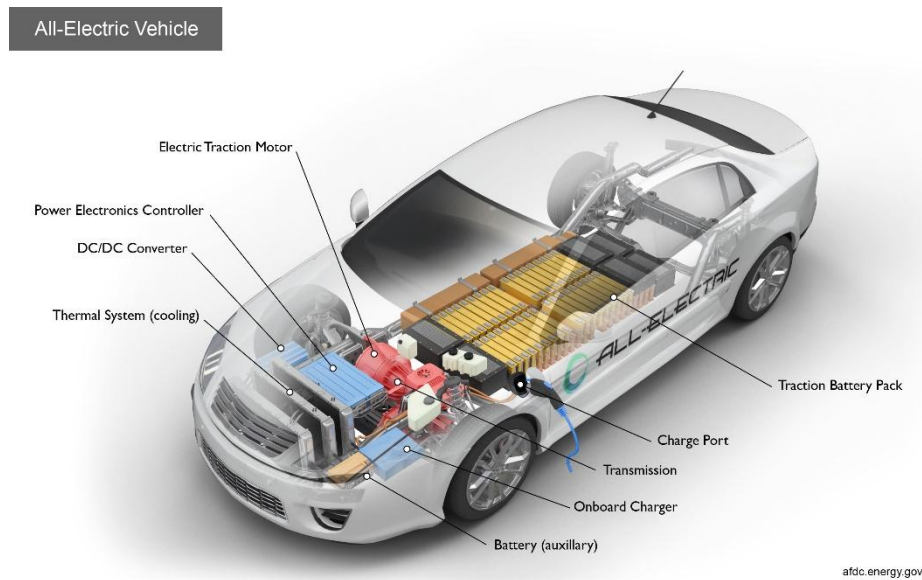

Figure 2 Key components in EV

1. MOTORS

There are various types of motors available for electric vehicles: DC motors, Induction motor, DC brushless motor, Permanent magnetic synchronous motor, and Switched reluctance motor.

1. DC motors: It is a classical and most used motor and has been used in motor control for a long time and continues to be relevant. All the power involved in the electromechanical conversions is moved to the rotor through non dynamic brushes which are in frictional contact with the copper segments of the commutator. However, it requires regular maintenance and has a shorter lifetime. Generally, it is most suitable for low power applications. It has found applications in electric wheelchairs, transporter, and micro-car. Today, almost all golf-carts are using DC motors where power levels are as low as 4KW.

2. Induction motor: It is one of the most popular AC motors. Moreover, it has a large market share in fluctuating speed drive application such as air-conditioning, elevator, and escalator. Many of the higher power electric vehicles, with power level requirements of more than 5kW use induction motor. Usually, a vector drive is used to provide torque and monitors the speed.

3. Direct Drive And In Wheel Motor

One of the major advantages of the Direct drive is that it reduces the losses incurred in the mechanical units to the drive train. The motor is directly connected to the shaft in a straight line to decrease requirements of transmission, clutch, and gear box. The in-wheel motor is there to turn the rotor inside out and is connected to the wheel's rim and the tire, however, there is no gear box and drive shaft. Fig 3 shows the in-wheel motor also called the wheel-hub motor. Its main advantage over others is that it is independent of the control of each wheel. Fig 4 shows the 4-wheeler drive vehicle. Each of the wheels can work at any speed and direction which not only aids in parallel parking but also the Anti-lock braking system (ABS) can be implemented effortlessly by this technology. Moreover, it has shown that it can successfully prevent spinouts. Many different types of motor can be utilized for in-wheel motor. The prominent one being switched-reluctance types. Its phase-winding is independent and therefore the fault clemency is much more advanced than any other. There is no permanent magnet in the motor, which reduces any interference by permanent field and the fluctuation of the permanent magnetic materials.

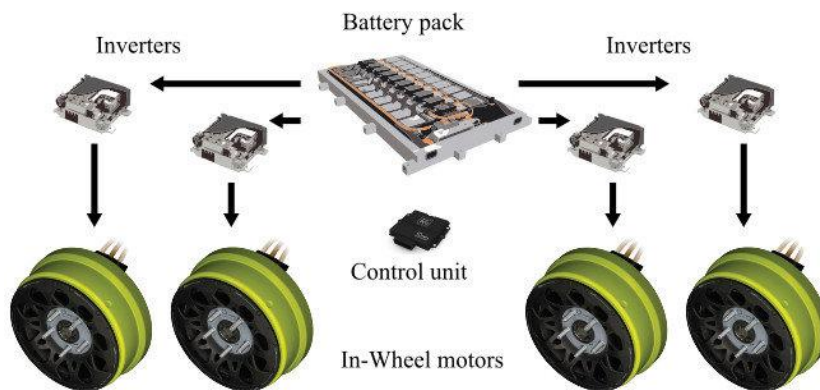

Figure 3 The in- wheel motor

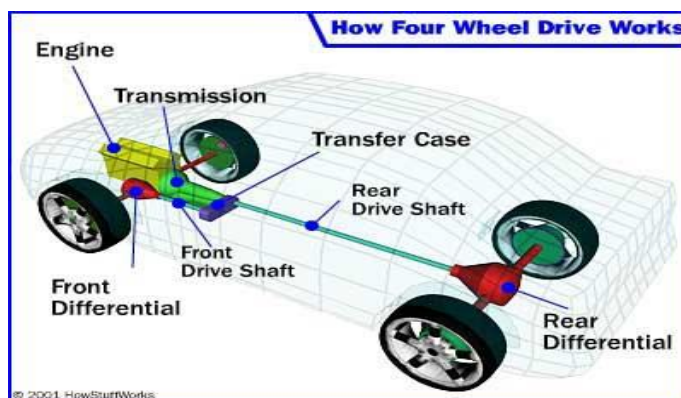

Figure 4 Four wheel drive

BATTERY CHARGING SYSTEMS

1. General charger:

The charger required for the battery system for slow charging or fast charging are both required to handle high power levels. The most used converter is the H-Bridge converter shown in Fig 5. The converter is desirable for its efficiency and has found application in charger and DC-DC converters.

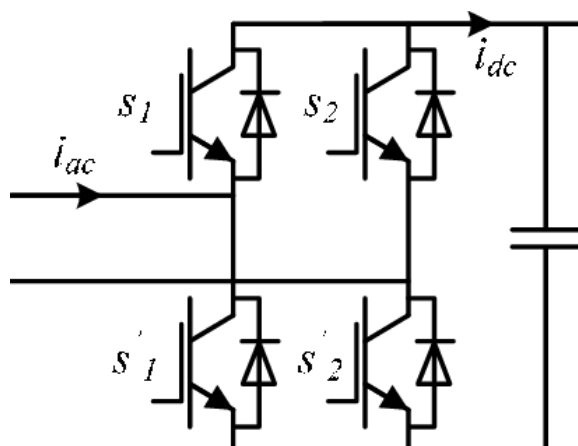

Figure 5 H bridge converter for charger

2. Ultra-capacitor charger:

The voltage on the ultra-capacitor charger varies from the full voltage to zero nits' and the energy storage varies from full to zero. It is important to note that, this is different from the battery as its voltage varies only within 25% limit. The capacitor voltage is internal point and is not in contact with the users. A tapped converter must be used as it will exhibit higher efficiency for power conversion. The efficiency of the power converter is higher than the transformer-isolated version and the structure is straightforward.

3. Battery management systems:

It is also referred to as BMS. The battery system is formed by several battery cells. They are connected in parallel or series according to the design. Each cell should be monitored and regulated. The conditioned observations include the voltage, current and temperature checks. The measured parameters are used to provide the decision framework for the system control and protection. Two limits are provided- the state of charge (SoC) and the State of Health (SoH). SoC is like the oil tank meter that provides the battery a charging condition and is measured by the information of voltage and current. The SoH is to account for the health or aging condition. There are a few definitions but the prominent one is:

$$\text{SoH} = (\text{Nominal Capacity} - \text{Loss of Capacity}) / (\text{Nominal Capacity})$$

Cell balancing is to ensure that each cell is operating under the same condition, or a regulation is used to charge or discharge each cell by the balancing control. This avoids the overloading of a particular cell. Energy management systems for ultra-capacitor systems, is made by a few capacitors in a combination with other energy storage devices such as battery. The same conditioning monitoring and management system will be used.

CONCLUSION

This paper discusses the latest developments in electric vehicles. The paper first describes general structure and discusses the energy storage. It then extends to the future vehicle components. The paper provides an overview of the recent EV work.

REFERENCES

-
- [1] Jones, W.D., "Hybrids to the rescue [hybrid electric vehicles]", IEEE Spectrum, Vol. 40(1),
 - [2] Jones, W.D., "Take this car and plug it [plug-in hybrid vehicles]", Spectrum, IEEE, Vol. 42, Issue 7, July 2005,
 - [3] Hyunjae Yoo; Seung-Ki Sul; Yongh Park; Jongcan Jeong, "System Integration and Power-Flow Management for a Series Hybrid Electric Vehicle Using Supercapacitors and Batteries", IEEE Trans. on Industry Applications, Vol. 44, Issue 1, Jan.-Feb. 2008, pp. 108 – 114.
 - [4] Haddoun, A.; Benbouzid, M. E. H.; Diallo, D.; Abdessmed, R.; Ghouili, J.; Srairi, K., "A Loss-Minimization DT Scheme for EV Induction Motors", IEEE Trans on Vehicular Technology, Vol. 56(1),
 - [5] Jinyun Gan; Chau, K.T.; Chan, C.C.; Jiang, J.Z., "A new surface-inset, permanent-magnet, brushless DC motor drive for electric vehicles", IEEE Transactions on Magnetics, Vol. 36, Issue 5, Part 2, Sept 2000, pp. 3810 – 3818.
 - [6] Chau, K.T.; Chan, C.C.; Chunhua Liu, "Overview of Permanent-Magnet Brushless Drives for Electric and Hybrid Electric Vehicles", IEEE Trans. on Industrial Electronics, Vol. 55, Issue 6, June 2008, pp. 2246 – 2257.