



Intelligent Reverse Braking System

Sachin Nanaware¹, Shivanjali Pawar², Sourabh Deshmukh³, Aditya Bhujbal⁴, ⁵Asst. Prof. D. J. Sangale.

^{1,2,3,4}Student Pes's College of Engineering Phaltan, Department of Mechanical, Phaltan Maharashtra, Phaltan, India - 415523.

⁵Mechanical Engineering Department, COEP, Phaltan, Satara, India - 415523.

ABSTRACT

The evolution of brakes has been impressive, and has included many new technologies throughout the years. In all new developments to the brake system, the number one priority is to improve auto safety and efficiency. Now a days cars having alarm system along with rear view cameras, when driving the car in reverse direction car gets too close to an obstacle an alarm is triggered which warns the car driver. Intelligent Reverse Braking System uses Infrared sensor (IR Sensor) to detect obstacle in vehicle's path, and disc brake for stopping the vehicle. If an obstacle is detected, the system can automatically stop the vehicle without the driver's effort. An experimental results based on tests taken under the different conditions showed that the Intelligent Reverse Braking system is consistently is able to stop the vehicle automatically.

Index Terms— Braking System, Auto safety, Infrared Sensor (IR).

1. Introduction

All of us are living in the era of technology, where Electronic Features and Technology are now an integral part of our life. When it comes to today's vehicles Automotive Technology are hugely important. Some of them serve as safety shields that you will hopefully never need to use, but you can take comfort knowing they are there. The ideal ones make things easier without driver distraction. In last decade, with increasing number of vehicles higher the rate of accident. Reportedly, one in four vehicle accidents occur when drivers are going in reverse. Most of these accidents involve vehicle damage, but bodily injury occurs as well. The National Highway Transportation Safety Agency calculates an average of 210 fatalities and 15,000 injuries are caused by back-up accidents every year.

2. Problem Statement



Now a days, accidents taking very frequent in India which occur mainly due to the inefficiency of driver to apply brakes at the right time. This also because of rise in population of vehicles which if not handled properly may create difficulty in driving vehicles on road.

3. Objectives

To evaluate the effects of rearview cameras, and rear braking systems on backing crashes.

4. List of Components

Sr.no	Component	Quantity
1	IR Sensor	1
2	Battery	1
3	Disc Brake	1
4	Limit Switch	1
5	Actuator	1
6	Control Unit	1

5. Design

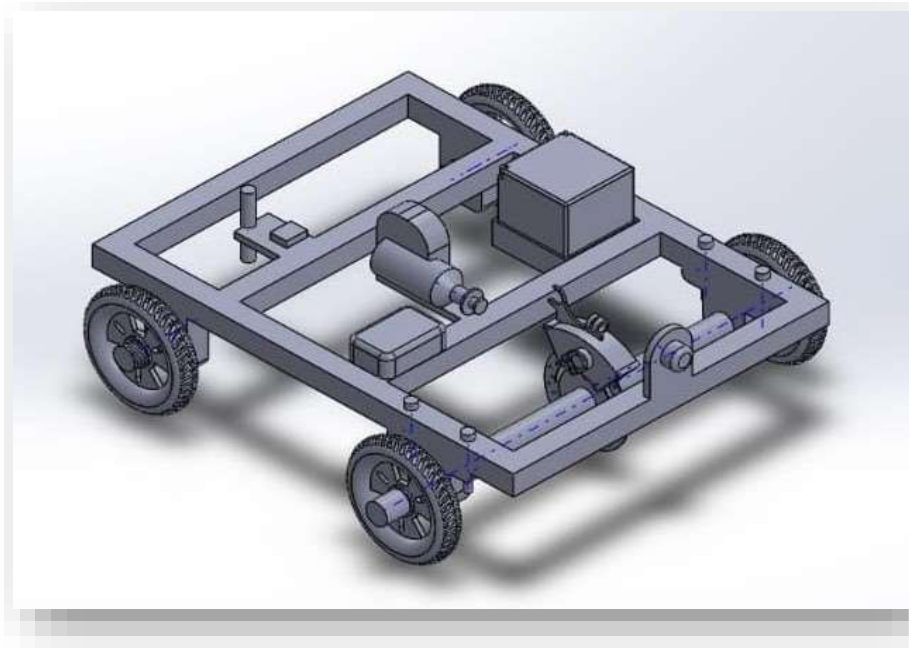

6. Working

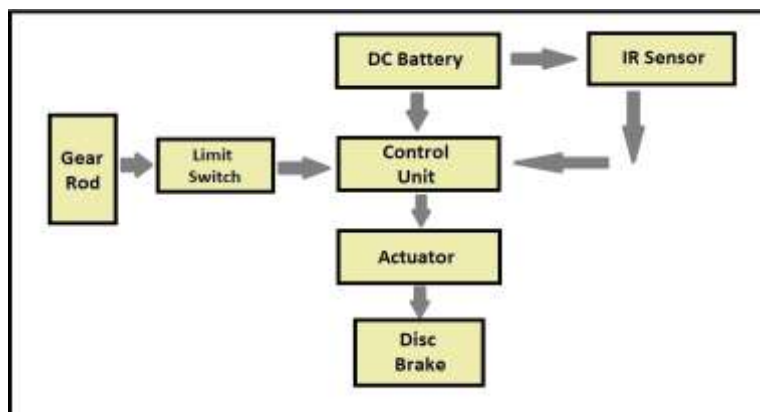

When we put the gear rod of vehicle in reverse, then the limit switch is attached to it, which activates the whole system. The ultrasonic transmitter circuit is to transmit the infra-red rays. If any obstacle is there in a path, the infra-red rays reflected. This reflected infra-red rays are received by the receiver circuit. The ultrasonic receiver circuit receives the reflected ultrasonic rays and giving the control signal to the control circuit. Control circuit is

used to actuate electric actuator. Electric actuator operates the disc brake and car stops automatically.

7. Advantages and Applications

Advantages: -

- Less power consumption It does not require electricity
- Free from wear adjustment.
- Less skill drivers is sufficient to operate.
- It gives very simplified operation
- Brake cost will be less.
- Installation is simplified.

Applications: -

- For Automobile application.
- Industrial application.

8. Result and Conclusion



Fig. Intelligent Reverse Braking System

The braking distance is the main factor considered in this system. Braking distance for a particular speed is the distance between the point of application of the brakes and the point at which the vehicle comes to a complete stop from the present speed.

It is calculated by using following formula,

$$\text{Braking Distance} = V^2 / 2\mu g \text{ (meter)}$$

Where,

V= Velocity of the vehicle (m/s)

μ = Coefficient of friction of road = 0.4

g = Acceleration due to gravity = 9.81(m/s²)

In this formula the condition of brakes and the road conditions are not considered for coefficient of friction μ .

Table showing braking distance:

Sr. No	Velocity (Km/hr)	Braking Distances (m)
1	60	7.64
2	50	6.37
3	40	5.09
4	30	3.82
5	05	0.6

Table. Velocity vs. Braking Distance

9. Acknowledgment

We would like to express our gratitude to our project guide D.J. Sangale. His immense knowledge and plentiful experience have encouraged us in all the time of our academic research. We truly appreciate and value his esteemed guidance and encouragement from the beginning to the end of this work and for his unwavering moral support and motivation during the entire work.

References

- [1] Dev Kocchar, Considerations in HMI Design of a Reverse Braking Assist (RBA) System. DOI: 10.4271/2013-01-07
- [2] Vrushali Ashish Shah, Rushabh Sheth, Tarpan Kothari. Design & Development of INTELLIGENT REVERSE BRAKING SYSTEM. Published in May 2021.
- [3] Bimba Manufacturing Company's Pneumatic Application and Reference Handbook. Published in January 2012.
- [4] 'Braking System History' by Daniel Patrascu, 20 May 2009.
- [5] 'Compendium of HLDI collision avoidance research' Bulletin Vol.37, No.12: December 2020.
- [6] T.-H. S. Li, S. J. Chang, and Y. X. Chen, "Implementation of human-like driving skills by autonomous fuzzy behavior control on an FPGA-based car-like mobile robot," IEEE Trans. Ind. Electron., vol. 50, no.5, pp. 867-880, 2003.
- [7] <https://www.autoevolution.com/news/braking-systems-history-6933.html>
- [8] www.Profc.udec.cl/~gabriel/tutorials.com
- [9] www.carsdirect.com/features/safetyflatures