



ARDUINO BASED DATA LOGGER

Chetan Matkar¹, Yashashree Shrivastav², Dishant Chavhan³, Ganesh Nale⁴, Prof. Ekeshwari A. Rangari⁵

^{1,2,3,4}Students, B.E. Electrical Engineering, J.C.O.E.T., Yavatmal

⁵Assistant Professor, Electrical Engineering Department, J.C.O.E.T., Yavatmal

ABSTRACT

Humidity and Temperature are crucial parameters for the optimal response of biological systems e.g. each has its own impact on growth and production of quality crops. There are several techniques of measuring humidity and temperature. In this work, a low cost six- multipoint temperature data logger was developed. However the most important thing is that all the systems recorded the same temperature flow pattern. This indicates that the systems actually senses change in the surrounding effectively. A code was generated using the computer with the appropriate Arduino program and sent to the Arduino microcontroller for running the circuit. In relation to the alcohol thermometer, the designed system shows an accuracy of $\pm 0.40^{\circ}\text{C}$ at temperatures below 300°C and $\pm 1.850^{\circ}\text{C}$ at temperatures above 300°C . The system gives room for effective and adjustable temperature data logging procedure. Hence, the system is recommended for use in monitoring low temperature systems.

Keywords - Temperature, Data-logger, sensor, arduino, thermometers.

1. INTRODUCTION

This project is based on the idea of storing environmental variables like temperature, humidity and many other into an SD card and into an excel sheet. Environmental parameters are crucial for monitoring biological systems. Among all the parameters, temperature and humidity are the most essential variables which have great impact on various aspects of human and these require monitoring in order to draw insights for future predictions. Temperature and humidity are required to be monitored in areas like health, hygiene, laboratories, halls, farms, to check quality of food during production and processing, for the nurtured growth of plants. Apart from these parameters a data logger can also monitor many other variables like water level monitoring, fire monitoring, wind monitoring and other similar parameters can be monitored.

2. LITERATURE SURVEY

1. Understanding of temperature flow/state during a certain time is needed in various applications. Temperature level can affect various types of measurement recorded, hence, temperature must be maintained within certain limits to achieve repeatable results, reduce the cost of tedious corrections and meet regulatory and correctness requirements [1].
2. With the desired temperature requirements in every field especially in agricultural productions, it is becoming more and more important for measuring and controlling of the temperature [2].
3. This leads to the problem of finding suitable measurement devices with the least hassles in obtaining temperature data considering that most measurements are carried out for long periods to cater for changing thermal pattern over different times/seasons. Most low-cost temperature measurement devices are hand-held and unsuitable for such work while the sophisticated ones are quite expensive [3].
4. Microprocessors, solid state sensors and fully featured software, which maximize accuracy) in which values from a sensor are recorded and stored at regular intervals [2].

3. HARDWARE DESCRIPTION

3.1 Arduino

Arduino is an open- source microcontroller- built programmed prototyping board as shown in Fig.1 that can be arranged utilizing the Arduino IDE. It contains of together a substantial programmable circuit board and program (or IDE). In the Arduino family, the Uno is one of the foremost common sheets. The foremost vital components of Arduino Uno are: 1. The USB Connector: It could be a printer USB harbour that's utilized to weight a

program onto the Arduino Uno board from Arduino IDE.. It can too be charged with a battery or an AC-to-DC connector. The Arduino Uno is fueled by a 5 volt supply, but it can handle up to 20 volts • The microcontroller The Arduino Uno's brain, which may be a unmistakably obvious dark rectangular chip on the board with 28 pins, serves as the controller.



Fig.1 Arduino Uno

3.2 Temperature and Humidity Sensor

DHT11 could be a temperature and mugginess measuring sensor, it contains 4 pins to be specific, VCC, GND, Information stick and a NC stick shown in fig. 2. The sensor employments an 8-bit microcontroller to show the benchmarks as serial information and an NTC (negative temperature coefficient thermistor) within the sensor measures

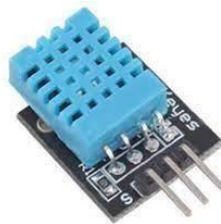

Fig. 2 DHT11 Sensor

the temperature. This sensor has simple meddle with microcontrollers because it has factory calibration. The sensor includes a capacitive stickiness recognizing component for distinguishing humidity, this capacitor has 2 tests and the dielectric medium between them could be a dampness holding substrate. The advantage of this sensor is ultra-low- taken a toll temperature and stickiness sensor. But, compared to other sensors like DHT22 usually less exact and precise. For, communication between the microcontroller and sensor a drag resistor (5k to 10k ohm) is investigated.

3.3Liquid crystal display

Liquid-Crystal Show (LCD), appeared in Fig. 3, may be a level- board show or other electronically tweaked optical gadget that employments the light-modulating properties of liquid crystals combined with polarizers. Fluid crystals don't transmit light specifically, instep employing a backdrop illumination or reflector to create pictures in color or monochrome. LCDs are accessible to show subjective pictures (as in a general-purpose computer show) or settled pictures with moo data substance, which can be shown or covered up, such as preset words, digits, and seven- fragment shows, as in a computerized clock. LCDs can either be



Fig. 3. Liquid Crystal Display for Displaying Readings

ordinarily on (positive) or off (negative), depending on the polarizer course of action. For illustration, a character positive LCD with a backdrop illumination will have dark lettering on a foundation that's the color of the backdrop illumination, and a character negative LCD.

3.4 IDE

The brain part of the building monitoring system, the Arduino IDE (integrated development environment), is a software development environment or software application for Arduino where users can write different kind of computer programs and test. The program (codes) written in IDE, when uploaded into the Arduino microcontroller determines what and how the system works. The Arduino IDE comes with a 'built-in code parser' that studies the validity of the written codes before sending it to the Arduino. The compilation and translation work is done in IDE after checking the validity of codes. After translating the code, the IDE uploads the program to the Arduino microcontroller.

4. WORKING

The below Fig. 4 shows working model of the project. The connections are made as per the circuit diagram. Arduino uno is connected to DHT11 sensor, RTC clock module and an SD card module with the help of wires and a bread board.

We need to connect the three pins (VCC, GND, DATA) of DHT11 sensor to 5V, GND, pin 7 of Arduino respectively. Next an SD card is to be inserted in the SD card module with the necessary text file and then the four pins (MISO,MOSI,SCK,CS) are to be connected to pin 11, 12, 13, 4 respectively of the Arduino.

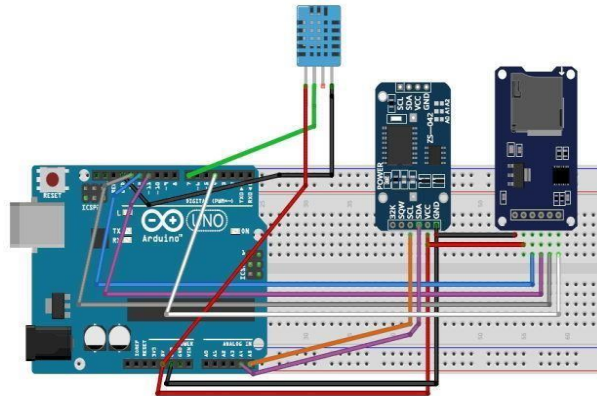

Fig. 4 Project Module

Then RTC clock module pins (SCL, SDA) are to be connected to Arduino pins A4, A5. After all the necessary connections, PLX-DAQ software is to be installed and then a spreadsheet will be created on desktop. For the live monitoring of the sensor values we need to connect to the Arduino board through this sheet's communication tab. After connecting with exact port number and baud, we can see the data, date, time values automatically filling in the rows of the excel sheet.

5. RESULT AND DISCUSSION

This study sought to first design, data logging of humidity and temperature and raise a light (from an LED) and a sound alarming (from a sound buzzer). To achieve this, the components that include the Arduino Uno, resistors, LED, LCD and Humidity and temperature sensor were fixed to the breadboard and connected as described in chapter three. A jumper wire was connected from the 5 volts' port from the Vcc port in the microcontroller chip to the positive channel of the breadboard. Another cable was grounded to the negative terminal of the breadboard from the GND port of the chip.



Fig. 5 A humidity and temperature sensor with display of distances on the Liquid Crystal Display.

When the power was connected to the circuit, LCD produced a green yellow light and it displayed as the details of the project followed then by the time, date, temperature and relative humidity values as in Figure 12 (Temperature, 23.6 °C and Relative Humidity as 95.0%).

6. CONCLUSION

In these days data has got a lot of importance, in every aspect of life we need to data store and draw insights from it to make future predictions in various fields. So, Arduino based data logger is a small- scale attempt to store the data with nicely calibrated values. This data logger is very low-cost. In this data logger we limited sensing variables to temperature and humidity, this can be expanded as per our needs. This project has a lot of scope for improvisations and changes can be made as per the necessity, this makes it very flexible to use. This approach has the following benefits: firstly, it is professional and accurate for real-time temperature and humidity nursing. Second, the system is entirely digital, with a complete storage arrangement for data that can be used for further study.

7. FUTURE SCOPE

The device will continuously track the environment parameters, informing the user of any changes at a predetermined interval of time. This encourages the user to keep a closer eye on the surroundings. However, the device was designed for a minimal area, and although the device is well adjusted, there is a risk that the readings may be off because the sensor could be compromised when exposed to higher temperatures.

REFERENCES

- [1] Sagarkumar S. Badhiye, S. S., Chatur, P. N. and Wakode, B. V. "Data Logger System: A Survey", Intl. Journal of Computer Technology and Electronics Engineering, 2008, pp 24-26.
- [2] Abrar, M. D. and Patil, R. R. "Multipoint Temperature Data Logger and Display on PC through Zigbee using PSoC", International Journal of Advanced Research in Computer and Communication Engineering, Vol. 2, Issue 9, 2013, pp 3382 – 3391
- [3] Sharan, R. V. "Development of a Remote Automatic Weather Station with a PC-based Data Logger", International Journal of Hybrid Information Technology, Vol.7, Number 1, 2014, pp.233-240.
- [4] Waghmare, M. B. and Chatur, P. N. "Temperature and Humidity Analysis using Data Logger of Data Acquisition System: An Approach", Intl. Journal of Emerging Technology and Advanced Engineering, Vol. 2, Number 1, 2012, pp 102-106.
- [5] Temperature Product group. "Temperature Sensors: Advantages and Disadvantages" http://measspec.com.cn/downloads/Temperature_Sensor_Advan_tages.pdf, Accessed on October 15, 2015.
- [6] Vinod, S., Raja, M. and Sailaja, D. "Air Pollution Check in Vehicles by Using GSM and GPS", Intl Journal of Professional Engineering Studies, Vol. 5, Number 3, 2015, pp 14-17.
- [7] Shelar, M., Singh, J. and Tiwari, M. "Wireless Patient Health Monitoring System", Intl Journal of Computer Applications, Vol. 62, Number 6, 2013, pp 1-5.
- [8] Divakar, V. "Design and Implementation of Microcontroller Based Temperature Data Logging System", Intl. Journal of Engineering and Advanced Technology, Vol. 3, Issue 2, 2013, pp 129-135.
- [9] Vandana, W., Madiwale, G. and Awasthi, N. "An Efficient Data Logger System for Continous Monitoring And Traceability of Cargo: Application of GPS and GSM Technology", Intl. Journal of Research in Engineering and Technology, Vol. 3, Number 6, 2014, pp 569- 572.
- [10] Aneja, B. and Singh, S. "Review of Temperature Measurement and Control", Intl. Journal of Electrical and Electronics Engineers, Vol. 3, Number 2, 2011, pp 29- 37.