



## **ELECTRIC SKATE BOARD**

***Prof. Mr. Bhausaheb N. Rajole<sup>1</sup>, Shubham Avhad<sup>2</sup>, Prachita kuwar<sup>2</sup>, Shubham Suryawanshi<sup>2</sup>***

<sup>1</sup>Assistant Professor, Department of E&TC Engineering, MVPS's KBTCOE, Nashik

<sup>2</sup> MVP's KBTCOE, Nashik, Savitribai phule university , Pune

---

### **ABSTRACT**

This project is an alternate solution to the increasing use of non-renewable energy resources which are leading to various problems such Traffic problems, Parking space problems, emissions of gases due to the burning fuels, noise pollutions which occurs in cities during peak rush hours. People tend to use their private vehicles even for the smallest commutes of 2-3km around cities contributing to the traffic problems. Thereby we are introducing E-SKATE board as an alternate solution in order to tackle these problems. this paper is a complete interpretation about this rechargeable electric skate board. The focus of this paper is to minimize modern day traffic problems and introduction of e-skate board as an alternate solution of travel for distances cutting done the use vehicles which run on fuels.

**Keywords:** Rechargeable Electric skate board, DC Motor, Controller, RPM, PWM, Drivers, Batteries

---

### **1. INTRODUCTION**

The Electric Skate Board is a modern-day innovation which is completely rechargeable and has a battery backup of 2-3 hours in one single use. The size of this skate board is small as compared to any commercial vehicle on the road. As the size is small it solves our first problem of parking space. It has a lithium-ion 7s2p battery pack which is completely rechargeable. Being completely rechargeable it solves the problem emission of fuel directly into air which makes it eco-friendly. As the area occupied by E- skate board on road is very small as compared to any two- wheeler and car so one can easily travel on road without causing any traffic jam.

It can be effortlessly used on roads, college campus, large scale as well as small scale industries as a medium of transport. For an instance if one wants to buy groceries but the location is 1.5 km away from his/hers place than this E-skateboard is best to reach their destination excluding the use of vehicle.

The hardware used to design consist of DC Motor (RS-775) is a high torque motor which is generally used in Robotics, quad-copters and in various industrial devices.

The E-skate board is great motion towards adopting and adapting an eco-friendly mode of transport for small commutes. This innovation has a bright further scope upon interfacing it with software and IOT. The below figure shows the real depiction of our project e-skate board.



---

## 2. RELATED WORK

### Hardware component description:

It consists of DC Motor, DC Motor Controller, Lithium-ion Battery pack, BMS (Battery Management System), Battery capacity and Voltage indicator.

### Skate Board mounts include:

- a) Skateboard Wheels
- b) Skateboard Riser Pads
- c) Skate Trucks
- d) Skateboard Gears
- e) Deck
- f) Grip Tape

---

## 3. HARDWARE COMPONENT

- **DC Motor:**



fig 1.2 RS-775 Brushed DC Motor used

The RS-775 dc motors have a standard size of 67 x 42 ) mm. The 42 mm is the outer diameter as the motor is cylindrical, whereas 67 mm is its height. The number 775 stands for this standard size.

- **DC Motor Controller**



Fig.2. Motor Controller

DC Motor Controller has a voltage between 9V-20V Dc It has a maximum current of 20A. And frequency of 25 KHz.

- **Li-ion Battery**



**Fig 3- Li-ion Battery**

It is a 7S2P battery pack Where, 7S mean 7 batteries connected in series and 2P means rows of 7 batteries connected in series are connected in parallel with each other.

- **BMS :**



**Fig 4 - Battery Management System (BMS)**

BMS of a the battery pack is the most cleverest component it helps in protection and security of the battery pack for overcharging , over discharging and heating of the battery.

- **Battery capacity / voltage meter indicator:**

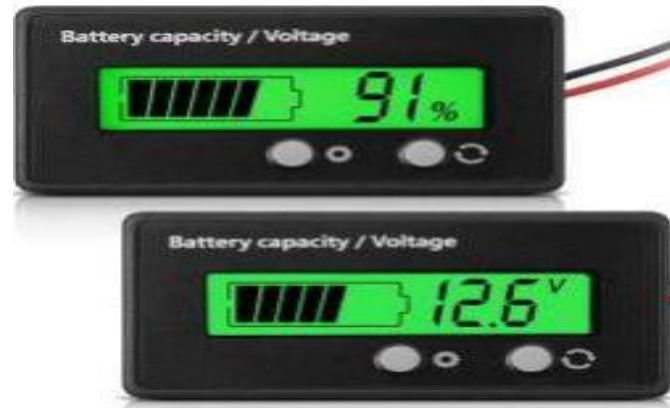

**Fig 4: Battery capacity / voltage meter indicator**

The LCD display of this component represents the battery left in the attery pack and voltage used.

- Working:

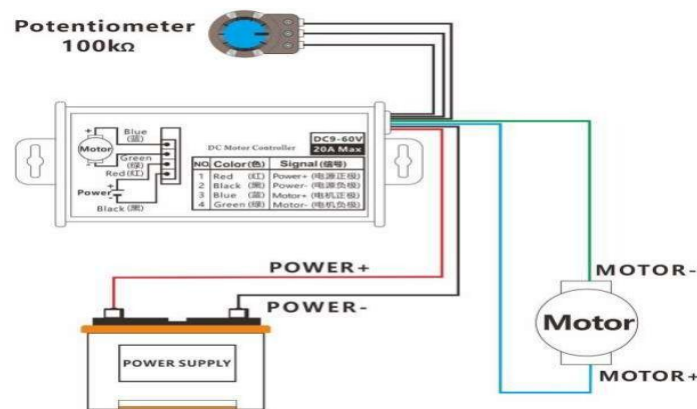

**Fig 5 : Circuit Diagram**

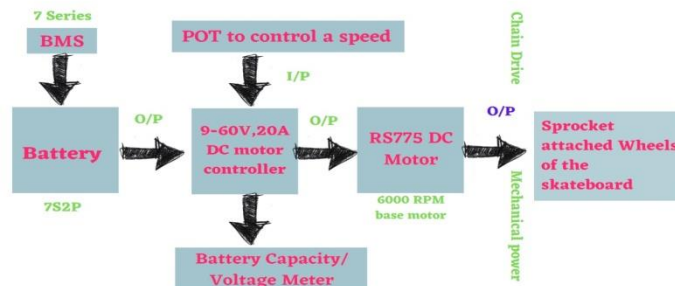

**Fig 6 : Block Diagram**

It uses a Chain Sprocket drive. this drive makes the skateboard more efficient to carry heavy weight without any breakdown. The DC motor is connected to the motor controller it helps motor to regulate speed and prevents liability in worse case. A Potentiometer is connected to DC motor control drive. The main purpose of this potentiometer is to control speed of motor. it acts as a speed regulator of the motor. The speed of the motor can be varied by rotating the potentiometer .In order to provide power to the skateboard a BMS of 7s2p pack of rechargeable lithium – ion battery pack is designed. Here the role of BMS (Battery Management system) is look after the safety and security of all the critical parameters of the battery. being rechargeable it gives a battery back-up of 3 hrs.

The working of the E-skate board is very simple and easy. Its working is so uncomplicated that any person irrespective of their age group can use this skate board. To start the E-skate board one has to simply rotate the rotary knob (pot) is mounted on the handle of the E-skate board than it starts to move with slow speed. The speed of the E-skate board can be varied by rotating the pot. In order to stop the E-skate board pot has to be brought in the initial position.

#### 4. LITERATURE SURVEY

The E-skate board is specially designed for short commutes around a college campus, inside city, around and inside large scale and small-scale industries. Its design is compact let it is very handy. It has an excellent build quality. The extra-add Ons include wheels grip liners for strong hold and extra grip while using it on the roads. It also has rubber pads for height and extra ground clearance. It also has a grip tape which made of adhesive sandpaper material which is placed at the top of board. It is also equipped with a head light and tail light in case one has to travel during night.

Every care was taken while designing the E-skate board so that the rider has the best experience while riding it. E-skate board has the full potential to work in any kind of weather. The battery-pack of the e-skate board is completely chargeable .it comes with a charger of 29V. It has BMS(Battery Management System) which is the alert and the cleverest part of battery pack. It looks after the safety and security of the battery pack in case of overcharge, over-discharge and temperature of cells which together form a battery pack. It has a separate horn mounted on the handle incase one has to go through crowded places.

The working of the E-skate board is very simple and easy. Its working is so uncomplicated that any person irrespective of their age group. To start the E-skate board one has to simply rotate the rotary knob (pot) is mounted on the handle of the E-skate board than it starts to move with slow speed. The speed of the E-skate board can be varied by rotating the pot. In order to stop the E-skate board the pot has to be brought in the initial position.

The drive mechanism used in the project is Chain drives sprocket. Sprocket is a wheel with teeth and chain is fitted on the teeth. It has driver and driver sprocket. The reason behind choosing this mechanism is that it would handle a weight around 45 kg. In conclusion a complete finish product was made in this project.

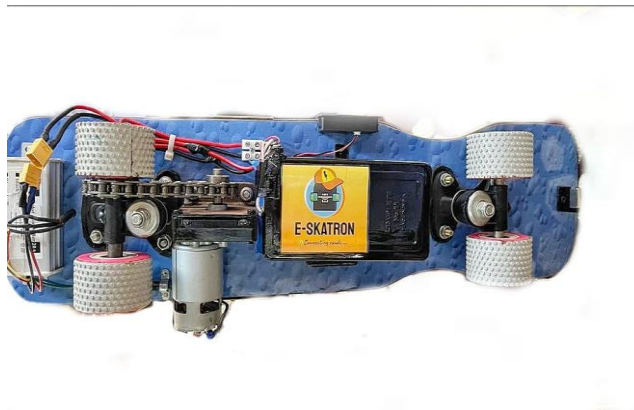
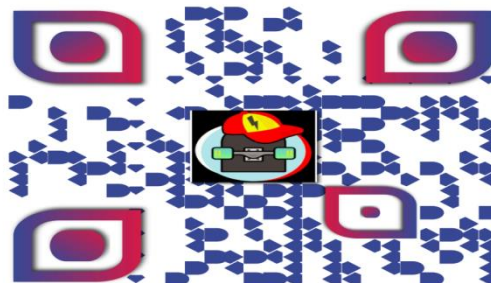

Fig 7: Bottom view of E-skate board

- QR code:



Scan me

This QR is specially generated so that you scan it know the specification and purpose of the project .

---

## 5. PROPOSED SYSTEM

In this methodology an electrical skate board was successfully executed. In this a battery pack of 7s2p is designed with BMS. A battery indicator was connected to the batteries which has a lcd screen interface in order to show the battery percentage and voltage in use during the action of E-skate board running on road. The sprocket drive in co-ordination with dc motor controller made and this project efficient. Additionally, a horn and headlight are at the handle and bottom of the e-skate board. This added system makes it a dynamic eco- friendly product.

---

## 6. CONCLUSION

This E-skate board has a capacity and capability to travel a short distance of 2-3km. with a battery backup of 2-3hrs. Due to its small size which is handy in nature it can easily pass-through traffic jams, by saving one's time. This effort of using electric skate board is contributing to environment by not causing pollution in air. A successfully working eco-friendly E-skate board was implemented.

### Acknowledgements:

We are thankful to our project guide Prof. Mr. Bhausaheb N. Rajole, Assistant Professor Electronics & Telecommunication Department for his invaluable guidance and cooperation that he gave us throughout our Project for inspiring us and for providing us all the lab facilities. We would also like to express our appreciation and thanks to HOD Dr. Vijay Manohar Birari and Principal Dr. Satish R. Devane and all our friends who have assisted us throughout our hard work.

---

### REFERENCES

- [1] International Journal of Emerging Technologies in Engineering Research (IJETER) Volume 5, Issue 3, March (2017) [www.ijeter.everscience.org](http://www.ijeter.everscience.org) ISSN: 2454-6410 ©EverScience Publications 195 Design and Fabrication of Electric Skateboard for Off Road Application. Fuzzy-PID controller for an energy efficient personal vehicle
- [2] Two-wheel electric skateboard International Journal of Electrical and Computer Engineering (IJECE) . SOLAR POWERED ELECTRIC SKATEBOARD International
- [3] Journal Of Innovations in Engineering Research And Technology [JIERT] [1] Agus Purwadi, Jimmy Dozeno, Nana Heryana, —Testing
- [4] Performance of 10 kW BLDC Motor and LiFePO4 Battery on ITB-1 Electric Car Prototype, I Procedia Technology., pp. 1074 – 1082, Nov.2013. [ Zhidong Zhang, —Design of Controller in Electric Bicycle, I
- [5] Modern Applied Science, Vol. 5, No. 5, October 2011. [ Darshil G. Kothari, Jaydip C. Patel, Bhavik R. Panchal.
- [6] Hybrid Bicycle, I IJEDR, ISSN: 2321-9939, Volume 2, Issue 1, 2014. [4 51 Nicolo Daina, Aruna Sivakumar., John W. Polak, I Modelling
- [7] electric vehicles use: a survey on the methods, I Renewable and Sustainable Energy Reviews., Vol. 68, pp. 447–460, 2017. M. J. Riezenman,
- [8] Arduino [2014], \_Arduino uno\*, [http://digital.csic.es/bitstream/10261/127788/7/D-c- %20Arduino%20uno.pdf](http://digital.csic.es/bitstream/10261/127788/7/D-c-%20Arduino%20uno.pdf). Datasheet: Arduino Uno, Date accessed: 2017-05-11.
- [9] CTMS [2017], \_Dc motor speed: System modeling\*. Date accessed: 2017-05-01
- [10] Johansson [2013], Elektroteknik, 2013 edn, Royal Institute of Technology. Department of Machine Design
- [11] Nedelkovski, D. [2016], \_How rotary encoder works and how to use it with arduino\*