



SMART WHEELCHAIR

Pragya Rai*¹, Shweta Bagade*², Vrunda Bankar*³

*Department of Electronics and Telecommunication, Maratha Vidya Prasarak Samaj's
Karmaveer Baburao Ganpatrao Thakre College of Engineering, Nashik, Maharashtra, India.*

ABSTRACT

Wheelchairs are used by the people who cannot walk due to physical illness, injury or other disability. Now-a-days development promises a wide scope in developing smart wheelchair. This project is to describe a smart wheelchair using smart phone to develop and control the rotation of wheel chair based upon user's movement. This wheelchair is fully automated and created specially for patients and elderly people. This is a smart wheelchair controlled by Arduino UNO with the support of some system like Bluetooth and Android application. This wheelchair is created to solve some ridiculous problems faced by physically disabled people to operate a manual wheelchair.

Keywords: *Arduino UNO, Bluetooth, Android application.*

1. INTRODUCTION

We were looking at a problem that disable population faces. Noticing that the disabled people in India get very little attention, we decided to aim our project towards them in order to help as much as we can. Disabled people rely heavily on their wheelchairs for transportation. The wheelchair frees them from their burdens and constraints and provides them with mobility. It has become a necessity to all, such that they cannot live without it anymore. For all these reasons, and in order to start a change, we decided to concentrate our effort on pinpointing the weaknesses in wheelchairs and improving them as much as we can. Our project will mainly feature one major idea in accordance with a few minor ones. The major idea that we will be trying to implement is to introduce the smart wheelchair for disabled people.

This smart wheelchair aims to provide aid to those handicapped and elderly people by providing them with some sort of mobility which would greatly help them and also reduce the burden of the person who helps to push the chair. So, we have designed a wheelchair which can be operated by smart phone with the help of Bluetooth module. Moreover, we have added a special feature in our wheelchair. This wheelchair provides obstacle detection hence reducing the chances of collision.

This major idea tends to solve the main problem faced by the persons with limb disabilities, who can't propel the wheel chair by themselves and they require some other source of control which is based on human sensing abilities. For these we need to use intelligent programming algorithms for controlling different sensors. This will make wheelchair an autonomous vehicle with smartness.

2. System Implementation

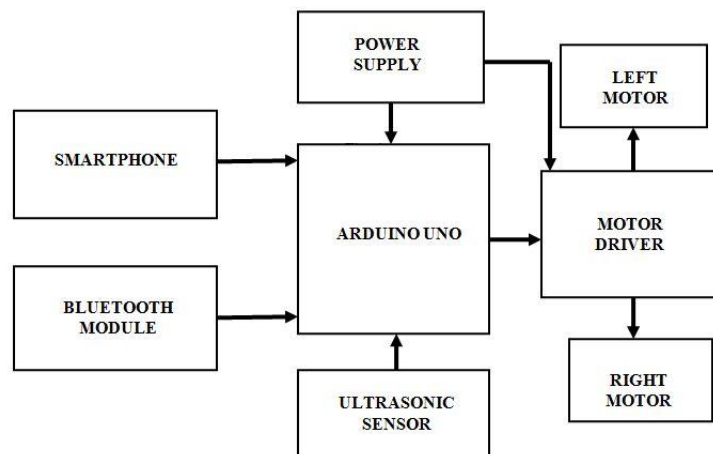

Fig. 1 - Block Diagram of Smart Wheelchair

The Arduino UNO is the main controller of proposed system. Here we have used 7.4V lithium ion battery for operation and two ultrasonic sensors one for collision detection purpose and the other for pit detection so that whenever a obstacle or pit is detected the buzzer starts buzzing and the user can move in some other direction. The wheelchair can be controlled with the help of smartphone application which gives commands like forward, backward, right and left. Also we can control the wheelchair using voice command. In case of emergency, there is a provision of buzzer which can be turned on/off using smart phone application.

2. WORKING

Smart wheelchair is multi functioned. This wheelchair can be controlled using android application and voice command given by user. One can use this wheelchair for various purposes. This chair can be used as panic alarm. If the person needs instant help, he/she can hit the buzzer so that someone can help him/her immediately.

This wheelchair can also automatically identify the obstacles and pit and makes decision to go with the obstacle free path. Once the Bluetooth Module receives the message, the command sent will be extracted and executed by the microcontroller attached to it and depending on the commands fed to the Motor Driver such as moving in forward, backward, left and right directions, the motors will function accordingly. The system will interpret the commands and control the Wheelchair accordingly via android application. Meanwhile, the ultrasonic sensor works while the circuit is on and makes sure the path has no obstacle and if any obstacle occurs it notifies the Arduino and stops wheelchair till further command is obtained from the user.

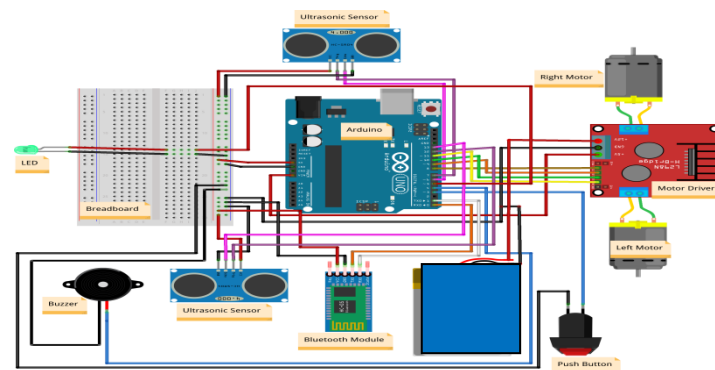
**Fig. 2 - Circuit Diagram**

3. RESULTS

By utilizing the system implementation, setup is done in fig. 3 demonstrates the interfacing of Android Smart phone application and the wheelchair.

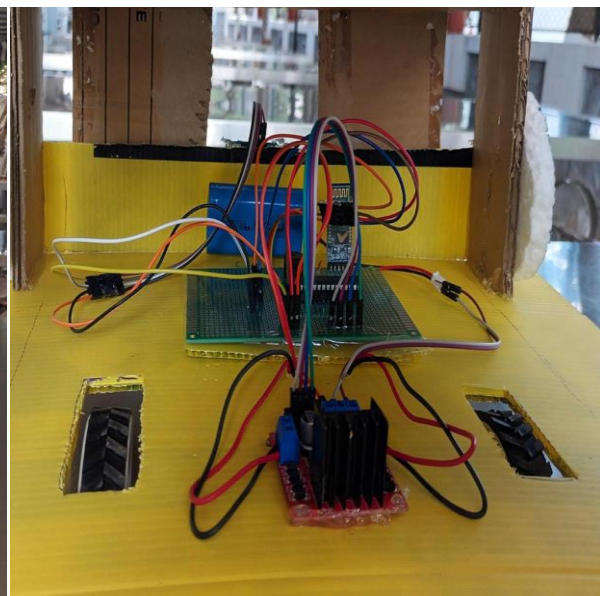
**Fig. 3 - Hardware Setup****Fig. 4 - Circuit Implementation**

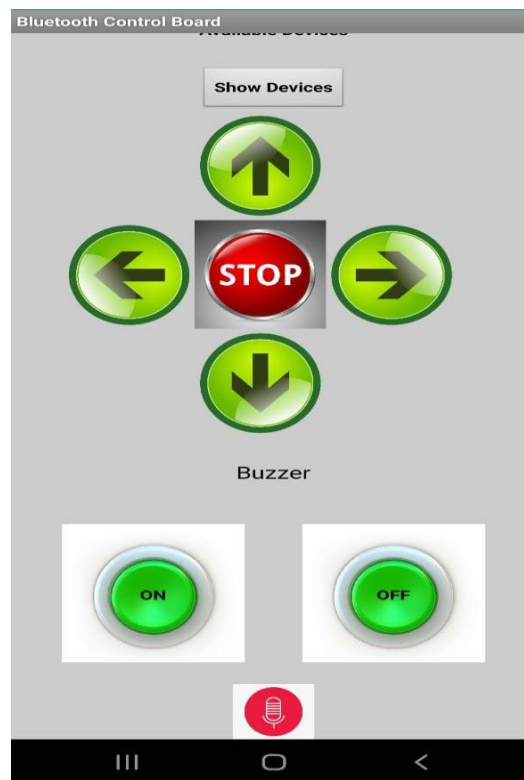

Fig. 5 - Android application for operation of wheelchair

4. CONCLUSION

In our project we designed a smart wheelchair which can be operated using smart phone application. The system was successfully implemented to move the wheelchair in forward, backward, left and right directions. Overall this wheelchair has the ability to move anywhere with no human efforts except giving it direction controls. This provides ease of operation as the system uses Smart phone. Obstacle avoiding feature is provided with the help of ultrasonic sensors.

5. FUTURE SCOPE

- The efficiency of voice command based wheelchair can be imported by neural based algorithm.
- Instead of using gesture recognition can use eye retina using optical sensor to move wheelchair in different directions.
- Tongue operated assistive technology is possible to access to android phone applications using Bluetooth link.

REFERENCES

- [1] Shraddha Uddhav khadilkar, Narendra Wagdarikar, "Android phone controlled Voice, Gesture and Touch Screen operated Smart Wheelchair", International Conference on Pervasive Computing (ICPC), 2015.
- [2] Rajesh Kannan Megalingam, Ramesh Nammily Nair, Sai Manoj Prakhya, "Automated Voice based Home Navigation System for the Elderly and the Physically Challenged", ICACT, 2011.
- [3] P.Sutha, S.Prabhu, S. Manikandan, S. Venkateshkumar, A. Stephen paul. " Android based Wheel chair using IOT" IJEIT, 2013
- [4] K. Sudheer, T.V.Janardhana rao, CH. Sridevi, M.S.Madhan Mohan, Voice and Gesture Based Electric-Powered Wheelchair Using ARM 2278-5841, Vol 1, Issue 6, November 2012.
- [5] Diksha Goyal and Dr. S.P.S. Saini "Accelerometer Based Hand Gesture Controlled Wheelchair", IJET, 2013
- [6] Rakhi A. Kalantri, D.K. Chitre Automatic Wheelchair using Gesture Recognition, International Journal of Engineering and Innovative Technology (IJEIT) Volume 2, Issue 9, March 2013