



International Journal of Research Publication and Reviews

Journal homepage: www.ijrpr.com ISSN 2582-7421

Home Automation Using Raspberry-PI

Ganesh Khandagale¹, Prajwal Pawar²

¹ UG student, Department of Electrical Engineering, Trinity college of Engineering Pune, Maharashtra, India

² UG student, Department of Electrical Engineering, Trinity college of Engineering Pune, Maharashtra, India

ABSTRACT

The concept of Internet of Things (IoT) requires the seamless connectivity of millions of heterogeneous devices. In today's World, implementation of IoT based smart home has drawn a huge attraction and become a prominent area of research. This research work presents an approach for smart home automation using IoT that can be controlled wirelessly. Home automation system means monitoring and controlling of home appliances remotely using the concept of internet of things (IOT). In this method we use mobiles or computers to control the basic home appliance and make it function through the designed web page with internet connection/local area network (LAN) servers. This type of home is also known as smart home. The concept of applying automation in the sectors of housing is selling like hot cake. Western countries have welcomed the concept of automation into their homes with open arms. Our country is keeping up with the pace of modernization too. Different approaches to automating homes have been implemented. The best among this is home automation system using IOT. IOT provides the feasibility of operating the home automation system from anywhere around the world using internet. It reduces use of excessive or unnecessary human efforts and improves the standard of living of the people in our society.

Keyword:-Automation, Time Saving, Energy Saving..

1. Introduction

1.1 Basic Overview

We live in an exciting time where more and more everyday things are becoming smart. Appliances have sensors and can communicate to other things and can provide control to more things.

Homes of the 21st century will become more and more self - controlled and automated due to the comfort it provides, especially when employed in a private home. A home automation system is a means that allow users to control electric appliances of varying kind.

Many existing, well-established home automation systems are based on wired communication. This does not pose a problem until the system is planned well in advance and installed during the physical construction of the building. But for already existing buildings the implementation cost goes very high.

With advancement of Automation technology, life is getting simpler and easier in all aspects. In today's world Automatic systems are being preferred over manual system. With the rapid increase in the number of users of internet over the past decade has made Internet a part and parcel of life, and IoT is the latest and emerging internet technology.

An automated home is sometimes called a smart home. It is meant to save the electric power and human energy. The home automation system differs from other system by allowing the user to operate the system from anywhere around the world through internet connection.

This does not pose a problem until the system is planned well in advance and installed during the physical construction of the building. But for already existing buildings the implementation cost goes very high. In contrast, Wireless systems can be of great help for automation systems.

1.1 Principle of Home automation:

Home automation refers to the automatic and electronic control of household features, activity, and appliances. In simple terms, it means you can easily control the utilities and features of your home via the Internet to make life more convenient and secure, and even spend less on household bills

Basic definition of the home automation means in the we used the equipment like fan, bulbs and geyser etc. we can operate by using Bluetooth Wi-Fi and apps.

1.1 BlockDiagram:

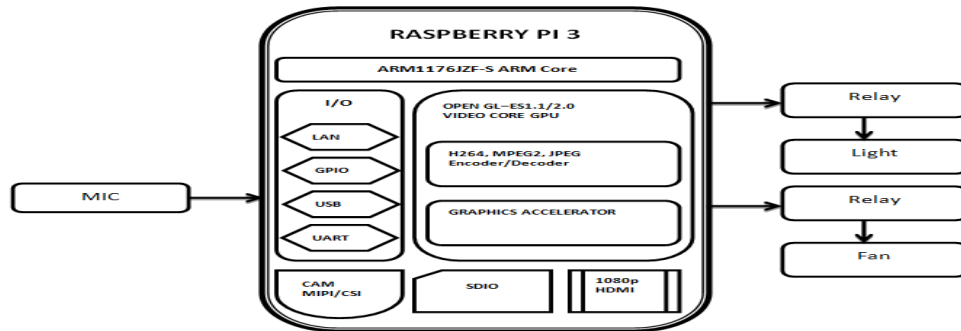

Fig1:Blockdiagramof home automation using raspberry-pi

In the circuit diagram of the project main components used

1) Arduino:

Arduino gives signal from Bluetooth module and its gives signal to LCD door , fan ,lamp. Its also takes signal from keypad. Bluetooth gives signal to the appliances to functioning according to signal

2) Bluetooth module:

Its gives signal to the appliances to functioning according to signal through Arduino. It also connect appliances to mobile phone.

3) Keypad:

Keypad is connected to Audunio , its function is typing the command and gives to the arduino.

4) LCD:

Its received input from arduino , its shows the running condition of appliances.

5) Door:

Door is connected to the Ardunio, and its operate according to signal.

6) Fan:

Fan is connected to the Ardunio, and its operate according to signal.

7) Lamp:

Lamp is connected to the Ardunio, and its operate according to signal

1.3 SimulationScheme

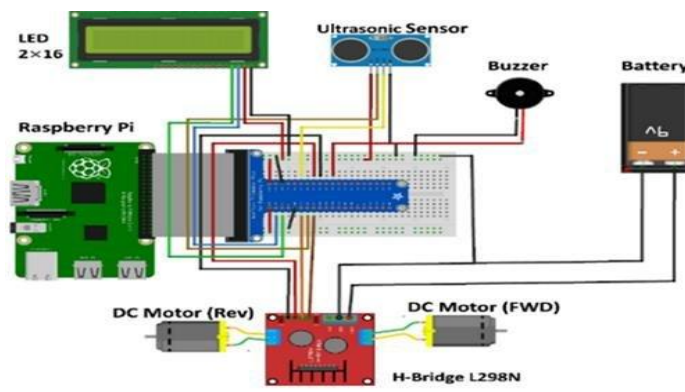

4. CONCLUSIONS

From this project we have studied about home automation system, how to automate equipment in the home and security equipment and energy saving and time saving from these devices.

REFERENCES

- [1] Baris Yuksekkaya, A. Alper Kayalar, M. Bilgehan Tosun, M. Kaan Ozcan, and Ali Ziya Alkar | A GSM, Internet and Speech Controlled Wireless Interactive Home Automation System |, 2006, IEEE Transactions on Consumer Electronics, Vol. 52(3), pp. 837 - 843.
- [2] Rozita Teymourzadeh, Salah Addin Ahmed Kok Wai Chan and Mok Vee Hoong | Smart GSM Based Home Automation System |, 2013, IEEE Conference on Systems, Process Control, Kuala Lumpur, Malaysia.
- [3] A. Alherbish, | Design and implementation of Home Automation System |, 2004, IEEE Transactions on Consumer Electronics, Vol. 50(4), pp. 1087-1092
- [4] M. Van Der Werff, X. Gui and W.L. Xu, | A Mobile based Home Automation System, Applications and Systems |, 2005, 2nd International Conference on Mobile Technology, Guangzhou, pp.5.
- [5] Mahesh.N.Jivani, | GSM Based Home Automation System Using App-Inventor for Android Mobile Phone | 2014, International Journal of Advanced Research in- Electrical, Electronics and Instrumentation Engineering, Vol. 3(9), pp. 1212-1218
- [6] Ketan Rathod, Prof. Rambabu Vatti, Mandar Nandre, and Sanket Yenare (2017), —Smart door security using Arduino and Bluetooth application |, International Journal of Current Engineering and Scientific Research, 4(11), 73-