



## Fault Detection and Monitoring in Power Lines using IOT

*C.Thangamuniyandi, A.Rajan Babu, Dr.R.Sivasangari*

Sree Sowdambika College of Engineering, Aruppukottai, Tamil Nadu, India

### ABSTRACT

The fault location detection has been a goal of power system engineers, since the creation of distribution and transmission systems. Quick fault detection can help protect the equipment by allowing the disconnection of faulted lines before any significant damage of the equipment. Automatic power line fault detection is a device that detects, identifies and locates the fault present in the power distribution line caused by various natural or manmade forces. This project mainly focuses on the section of power line that connects the transformer with customers. These faults are directly affects the customers so that it must be found out and rectified as fast as possible. This is done by placing individual units on certain points of the power line which consists of set of voltage and current sensors. Using sensor values, the system checks whether there is any faultis present on the line or not.

**Keywords:** IoT, Relay, PIC Microcontroller, Transmitter, Receiver.

### 1. INTRODUCTION

Currently, the electric power infrastructure is highly vulnerable against many forms of natural and malicious physical events [1], which can adversely affect the overall performance and stability of the grid. Additionally, there is an impending need to equip the age old transmission line infrastructure with a high performance data communication network, that supports future operational requirements like real time monitoring and control necessary for smart grid integration [2], [3]. Many electric power transmission companies have primarily relied on circuit indicators to detect faulty sections of their transmission lines. However there are still challenges in detecting the exact location of these faults. Although fault indicator technology has provided a reliable means to locate permanent faults, the technical crew and patrol teams still has to physically patrol And inspect the devices for longer hours to detect faulty sections of their transmission lines. Wireless sensor based monitoring of transmission lines provides a solution for several of these concerns like real time structural awareness, faster fault localization, accurate fault diagnosis by identification and differentiation of electrical faults from the mechanical faults, cost reduction due to condition based maintenance rather than periodic maintenance, etc.. These applications specify stringent requirements such as fast delivery of enormous amount of highly reliable data. The success of these applications depends on the design of cost effective and reliable network architecture with a fast response time. The network must be able to transport sensitive data such as current state of the transmission line and control information to and from the transmission grid. This research provides a cost optimized framework to design a real time data transmission network. To monitor the status of the power system in real time, sensors are put in various components in the power network. These sensors are capable of taking fine grained measurements of a variety of physical or electrical parameters and generate a lot of information. Delivering this information to the control centre in a cost efficient and timely manner is a critical challenge to be addressed in order to build an intelligent smart grid. Network design is a critical aspect of sensor based transmission line monitoring due to the large scale, vast terrain, uncommon topology, and critical timing requirements. Mechanical faults, cost reduction due to condition based maintenance rather than periodic maintenance, etc. The use of sensor networks has been proposed for several applications like mechanical state processing and dynamic transmission line rating applications [4]-[6]. To monitor the status of the power system in real time, sensors are put in various components in the power network [7]-[10].

\* Corresponding author. Tel.: 9442444613;  
E-mail address: [sivasangarianand@gmail.com](mailto:sivasangarianand@gmail.com)

## 2. Block diagram

In Fig. 1 shows the block diagram of wireless networking system. The transmission line infrastructure, wireless networking presents a feasible and cost effective solution for transmission line monitoring such as voltage and current. The several works and propose to improve the state of the art in transmission line monitoring by harnessing the power of wireless sensor networks for real time monitoring and control GSM is a cellular network, which means that mobile phones connect to it by searching for cells in the immediate vicinity. The GSM networks operate in four different frequency ranges. Most GSM networks operate in the 900 MHz or 1800 MHz bands. Some countries in the Americas (including Canada and the United States) use the 850 MHz and 1900 MHz bands because the 900 and 1800 MHz frequency bands were already allocated GSM has used a variety of voice codices to squeeze 3.1 kHz audio into between 5.6 and 13 kbps

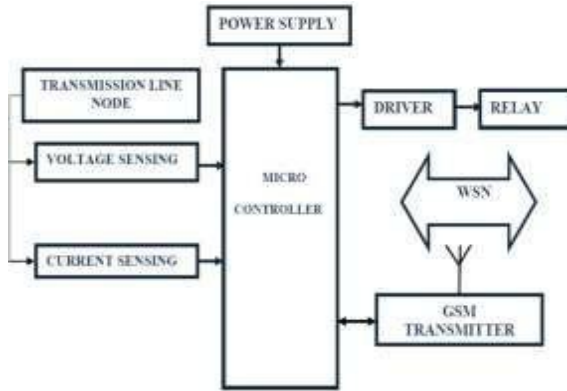

Fig.1: Block diagram

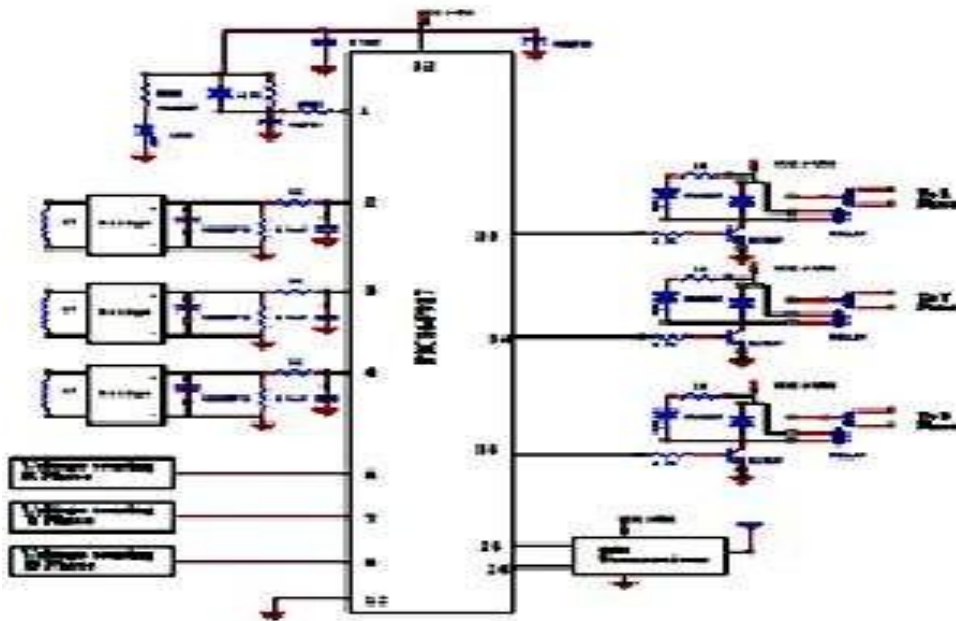
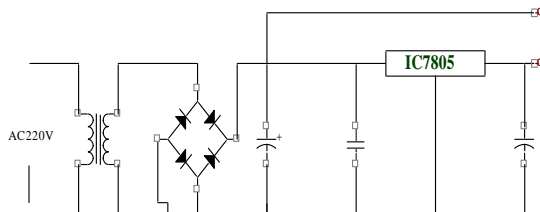

Fig.2: Circuit diagram

Originally, two codes, named after the types of data channel they were allocated, were used, called Half Rate (5.6 kbps) and Full Rate (13 kbps). These used a system based upon linear predictive coding (LPC). In addition to being efficient with bitrates, these codes also made it easier to identify more important parts of the audio, allowing the air interface layer to prioritize and better protect these parts of the signal installation and subscription costs.[20], [21]. In Fig. 2 shows the circuit diagram of wireless networking system.



**Fig.3: Power supply circuit**

In this circuits need two power supplies. The 78XX ICs are worked on regulated DC power 5V with GND. Relay driver worked on DC 12V with GND. This unit consists of transformer, rectifier, filter and regulator. The AC voltage typically 230v RMS is connected to a transformer which steps that AC voltage down to the level of the desired AC voltage. The Diode rectifier then provides a bridge rectified voltage that is initially filtered by a simple capacitor filter to produce a DC voltage. This resulting DC voltage usually has some ripple or AC voltage variations. A regulator circuit can use this DC input to provide DC voltage that not only has much less ripple voltage but also remains the same DC value even the DC voltage varies somewhat, or the load connected to the output DC voltages changes [22], [23].

### 3. . INTERNET OF THINGS

**Fig.4: Internet of things**

In Fig.4 shows the IoT. The user interface is through web pages that are created on the client-side, using HTML. JavaScript is used for validity checks of the information entered by the users. The client's browser parses the URL into a number of separate parts, including address, path name and protocol. A Domain Name Server (DNS) translates the domain name the user has entered into its IP address, a numeric combination that represents the site's true address on the Internet (a domain name is merely a "front" to make site addresses easier to remember). The browser now determines which protocol (t

The language client machines use to communicate with servers) should be used. Examples of protocols include FTP (File Transfer Protocol), and HTTP (Hyper Text Transfer Protocol). The browser sends a GET request to the Web server to retrieve the address it has been given. For example, when a user types `http://www.example.com/1.jpg`, the browser sends a GET 1.jpg command to example.com and waits for a response. The server now responds to the browser's requests. It finds the pessary files, runs the appropriate scripts, exchanges cookies if necessary, and returns the results back to the browser. If it cannot locate the file, the server sends an error message to the client. The browser, after receiving the HTML file, displays the webpage to the user.[24].

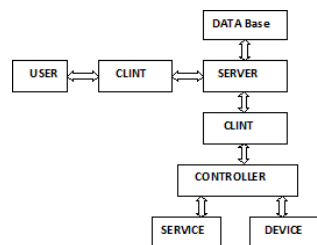
**Fig.5: Client server architecture**

The Internet is basically a client server system. In the retrieval of information that can be accessed using the internet, there are two important components: client, which requests the information and server, which stores it. Each side requires a piece of software to negotiate the exchange of data. During web page retrieval, at the client side, a browser like Netscape or internet explorer is used. The server side software performs the task of negotiating data transfers between clients and servers via hypertext transfer protocol (HTTP), the communications protocol of the Web. The different server software are available for various operating systems such as Microsoft Internet information Server (IIS) for Windows NT and the

Apache web server for Unix platform. The Fig.5 shows the client server architecture. The welcome page has a short form that will enable the user to log in to the system. The form has text fields for username and password entry. The user has to specify his/her username and password obeying the following rules. The Fig.6 shows the welcome pages of the IoT.

**Fig .6: Welcome pages**

**Fig.7: Control pages**

In Fig.7 shows the Control pages of the IoT. The menu page displays various buttons where he/she can select from a list of available menus provided by the system. On the menu page, the user can select DEVICE, SHUDDOWN and EXIT. On selecting device, the user can choose among devices to control. SHUDDOWN menu is provided to emergency off regarding the procedure to be followed. EXIT menu is provided to log out of the system. By sensing the voltage and current in this circuit, the short circuit is having the output in the range of high voltage and low current and the open circuit having the output in the range of low voltage and high current range.

#### 4. EMBEDDED SYSTEM

An embedded system is a combination of computer hardware, software and additional mechanical parts, designed to perform a specific function. An embedded system is designed to do a specific task within a given time frame, repeatedly, without human interaction. Embedded system do not need a complete operating system, but only the basic functionalities of an operating system in a real-time environment, that is, a real time operating system (RTOS). Frequently, embedded system does not have a user interface. PIC (Peripheral Interface Controller) is the IC which was developed to control the peripheral device, dispersing the function of the main CPU. When comparing to the human being, the brain is the main CPU and the PIC shares the part of which is equivalent to the automatic. However, the through out, the memory capacity is not big. It depends on the kind of PIC but the maximum operation clock frequency is about 29 MHz and the memory capacity to write the program is about 1k to 4k words. It is possible to make the compact circuit when using PIC [25], [26]

#### 5. CONCLUSION

In this paper, present an optimal formulation for a cost optimized wireless network capable of transmission of time sensitive sensor data through the transmission line Network in the presence of delay and bandwidth constraints. Our analysis shows that a transmission line monitoring framework using WSN is indeed feasible using available technologies. The proposed method with formulation is generic and encompasses variation in several factors such as asymmetric data generation at towers, wireless link reliabilities, link utilization dependent costs, non-uniform cellular coverage characteristics and requirements for cost optimized incremental deployment. The evaluation studies show that the main bottleneck in cost minimization is wireless link bandwidth. Further, in cases of increasing flow bandwidth, the limited wireless link bandwidth

leads to a feasible but expensive design due to increased dependence on cellular network to satisfy constraints.

## REFERENCES

- H.Li, G.W.Rosenwald, J.Jung, and C. Liu, "Strategic power infra-structure defense," Proc. IEEE, vol. 93, no. 5, pp. 918–933, May 2005.
- G. Vidhya Krishnan, R.Nagarajan, T. Durka, M.Kalaiselvi, M.Pushpa and S. Shanmuga priya, "Vehicle Communication System Using Li-Fi Technology," International Journal of Engineering And Computer Science (IJECS), Volume 6, Issue 3, pp. 20651-20657, March 2017.
- J.Chandramohan, R.Nagarajan, K.Satheeshkumar, N.Ajithkumar, P.A.Gopinath and S.Ranjithkumar, "Intelligent Smart Home Automation and Security System Using Arduino and Wi-fi," International Journal of Engineering And Computer Science (IJECS), Volume 6, Issue 3, pp. 20694- 20698, March 2017.
- V. C. Gungor and F. C. Lambert, "A survey on communication net-works for electric system automation," Comput. Netw. vol. 50, no.7, pp.877– 897, May 2006.
- P. Ramachandran, V. Vittal, and G. T. Heydt, "Mechanical state estimation for overhead transmission lines with level spans," IEEE Trans. Power Syst., vol. 23, no. 3, pp. 908–915, Aug. 2008.
- R.Nagarajan and S.Sathishkumar, K.Balasubramani, C.Boobalan, S.Naveen and N.Sridhar. "Chopper Fed Speed Control of DC Motor Using PI Controller," IOSR- Journal of Electrical and Electronics Engineering (IOSR-JEEE), Volume 11, Issue 3, Ver. I, pp. 65-69, May – Jun. 2016.
- P. Zhang, F. Li, and N. Bhatt, "Next-generation monitoring, analysis, and control for the future smart control center," IEEE Trans. Smart Grid, vol. 1, no. 2, pp. 186–192, Sep. 2010.
- J. Ausen, B. F. Fitzgerald, E. A. Gust, D. C. Lawry, J.P. Lazar, and R. L. Oye, "Dynamic thermal rating system relieves transmission con-straint," in Proc. IEEE 11th Int. Conf. Transmission. Distribution. Construction, Oper, Live-Line Maintenance (ESMO), Oct. 15–19, 2006.
- V.C.Gungor, L.Bin, and G. P. Hancke, "Opportunities and challenges of wireless sensor networks in smart grid," IEEE Trans. Ind. Electron., vol. 57, no. 10, pp. 3557–3564, Oct. 2010.
- R.Nagarajan and M,Saravanan. "Performance Analysis of a Novel Reduced Switch Cascaded Multilevel Inverter," Journal of Power Electronics, Vol.14, No.1, pp. 48-60. Jan.2014.
- S. Chandrasekar and Gian Carlo Montanari, "Analysis of Partial Discharge Characteristics of Natural Esters as Dielectric Fluid for Electric Power Apparatus Applications," IEEE Transactions on Dielectrics and Electrical Insulation Vol. 21, No. 3, pp.1251-1259 June 2014.
- S. Ullo, A. Vaccaro, and G. Velotto, "The role of pervasive and coop-erative sensor networks in smart grids communication," in Proc. 15th IEEE Mediterranean Electro tech. Conf. (MELECON), Apr. 26–28, 2010, pp. 443–447.
- S. Malhara and V. Vittal, "Mechanical state estimation of overhead transmission lines using tilt sensors," IEEE Trans. Power Syst., vol. 25, no. 3, pp. 1282–1290, Aug. 2010.
- Bose, "Smart transmission grid applications and their supporting infrastructure," IEEE Trans. Smart Grid, vol. 1, no. 1, pp. 11–19, Jun. 2010.
- R.Nagarajan and M,Saravanan "Staircase Multicarrier SPWM Technique for Nine Level Cascaded Inverter," Proceedings of the International Conference on Power, Energy and Control, IEEE Press, pp-668-675. 2013.
- K. Moslehi and R. Kumar, "A reliability perspective of the smart grid," IEEE Trans. Smart Grid, vol. 1, no. 1, pp. 57–64, Jun. 2010.
- K. S. Hung, W. K. Lee, V. O. K. Li, K. S. Lui, P. W.T. Pong, K. K. Y. Wong, G. H. Yang, and J. Zhong, "On wireless sensors communication for overhead transmission line monitoring in power delivery systems," in Proc. 1st IEEE Int. Conf. Smart Grid Commun. (Smart GridComm.), Oct. 4–6, 2010, pp. 309–314.
- Y. C. Wu, L. F. Cheung, K. S. Lui, and P. W. T. Pong, "Efficient communication of sensors monitoring overhead transmission lines," IEEE Trans. Smart Grid, vol. 3, no. 3, pp. 1130–1136, Sep. 2012.
- R.Nagarajan, S.Sathishkumar, S.Deepika,G.Keerthan a,J.K.Kiruthika and R.Nandhini, "Implementation of Chopper Fed Speed Control of Separately Excited DC Motor Using PI Controller", International Journal of Engineering and Computer Science (IJECS), Volume 6, Issue 3, pp. 20629-20633, March 2017.
- J. Chen, S. Kher, and A. K. Somani, "Energy efficient model for data gathering in structured multi clustered wireless sensor network," in Proc. 25th IEEE Int. Perform., Computed, Commune. Conf. (IPCCC), Apr. 10–12, 2006, pp. 8–388.
- Y. Yang, F. Lambert, and D. Divan, "A survey on technologies for implementing sensor networks for power delivery systems," in Proc. IEEE Power Eng. Soc. Gen. Meet., Jun. 24–28, 2007, pp. 1–8, vol., no.,
- Y. Yang, D. Divan, R. G. Harley, and T. G. Habetler, "Design and implementation of power line sensor net for overhead transmission lines," in Proc. IEEE Power Energy Soc. Gen. Meet. (PES), Jul. 26–30, 2009.
- R. G. Olsen and K. S. Edwards, "A new method for real-time monitoring of high-voltage transmission- line conductor sag," IEEE Trans. Power Del., vol. 17, no. 4, pp. 1142–1152, Oct. 2002.
- S.Gumbo and H. N. Muyingi, "Performance investigation of wireless sensor network for long distance overhead power lines; mica 2 motes, a case study," in Proc. 3rd Int. Conf. Broadband Commun., Inf. Technol. Biomed. Appl., Nov. 23–26, 2008, pp. 443–450.
- R.Nagarajan, R.Yuvaraj, V.Hemalatha, S.Logapriya, A.Mekala and S.Priyanga, " Implementation of PV - Based Boost Converter Using PI Controller with PSO Algorithm," International Journal of Engineering And Computer Science (IJECS), Volume 6, Issue 3, pp. 20477-20484, March 2017.
- J. G. Proakis, Digital Communications, 4th ed. New York: McGraw-Hill, 2000
- Van der Geer, J., Hanraads, J. A. J., & Lupton, R. A. (2000). The art of writing a scientific article. *Journal of Science Communication*, 163, 51–59.
- Strunk, W., Jr., & White, E. B. (1979). *The elements of style* (3rd ed.). New York: MacMillan.

- Mettam, G. R., & Adams, L. B. (1999). How to prepare an electronic version of your article. In B. S. Jones & R. Z. Smith (Eds.), *Introduction to the electronic age* (pp. 281–304). New York: E-Publishing Inc.
- Fachinger, J., den Exter, M., Grambow, B., Holgerson, S., Landesmann, C., Titov, M., et al. (2004). Behavior of spent HTR fuel elements in aquatic phases of repository host rock formations, 2nd International Topical Meeting on High Temperature Reactor Technology. Beijing, China, paper #B08.
- Fachinger, J. (2006). Behavior of HTR fuel elements in aquatic phases of repository host rock formations. *Nuclear Engineering & Design*, 236, 54.