



---

# **Radar Vision Based Controlling Alerts And Weapon Activation For Border Defense**

***M. Poojitha Yadav, Ommi Aravind, K. Navya***

*Gayatri Vidya Parishad College For Degree And Pg Courses(A)  
Rushikonda, Visakhapatnam-45, Andhra Pradesh, India*

---

## **ABSTRACT**

In this project of Radar vision-based controlling alerts and weapon activation, we are developing a system that could be a great help in enhancing the security of our border regions especially, the areas facing extreme climatic or terrain conditions where human deployment is a major peril. To curb such happenings the least we can do is to constantly monitor across the border and detect intrusions. It takes a lot of manpower to stretch over the border and constantly keep an eye, hence the need of the hour is to build such automated border surveillance which can eliminate manpower. Moreover, if something suspicious is detected by the system, it must be able to perform necessary actions by issuing an alarm alert and weapon activation system.

---

Keywords:24/7 Border surveillance, Automatic intrusion detection, alarm alert, Weapon Activation.

---

## **1. INTRODUCTION**

Today our major concern is the nation's border security. These borders are guarded by our soldiers. These soldiers encounter threats to their lives due to cross-border terrorism, drug peddlers, etc. Due to these malicious elements, the soldier's life is a huge risk, and many lose their life. If we could have saved even half of the soldier's life, we would have an even more brave force. These may not have been possible in past times, but today the scenarios are changing. This border surveillance system can not only assist the defense forces to enhance the security of border areas but also, can help save a considerable amount of labor and assets. It involves the use of advanced technology keeping in mind the cost-effectiveness of the constituent modules of the system with a goal that any infiltration recognized at the border can instantly be transmitted and results in a necessary move. Appropriate utilization of the system may help our border security forces to control those unwanted and suspicious exercises in a better and more accurate way.

### **1.1 EXISTING SYSTEM**

The existing system will not fully remove the responsibility of soldiers but shares the maximum responsibility and will reduce human efforts on the border. Using this system, we can identify how many strangers or terrorists are entering the border. The main objective of this existing system is to alert the soldiers about the number of terrorists entering or crossing the border. The main concept behind this existing system is known as "Visitor Counter" which measures the number of terrorists entering the border or crossing the border. This function is implemented using a pair of IR sensors.

### **1.2 PROPOSED SYSTEM**

The proposed system, which is an automatic border security system uses Arduino, ultrasonic sensor, IR sensor, and IOT as a border intrusion detection technique that uses IoT to alert the controller room. This system is fully automated and

needs only one or two persons for maintenance purposes. This system has ultrasonic sensors which are responsible for the detection of intrusion. As they are mounted over the section pillars. The sensors continuously rotate back & forth in the range of certain degrees (30-160) & show the intrusion over the radar with its location. Another set of sensors senses the intrusion & shows over the LEDs & activation of the alarm. As the sensors detect the intrusion RF transmitter sends a signal to the receiver. Once the control station gets an alert, the laser gun will fire toward the intruder & eliminate it

## 2. EMBEDDED SYSTEMS

Embedded systems are systems that accomplish a pre-defined or specified task. It is made up of both hardware and software. It's just a computer hidden within a product. It's just an electronic chip with a programmable hardware design. Embedded systems are devices that control, monitor, or aid the operation of equipment, machinery, or plants, according to a broad definition. The term "embedded" refers to their status as an important element of the system. In many situations, their integration is so deep that their presence is barely noticeable to the untrained eye. A general-purpose computer, on the other hand, could be used to control the functioning of a big, complicated processing plant and its presence would be visible. Computers or microprocessors are present in all embedded systems. However, when compared to a personal computer, some of these computers are quite rudimentary devices.

The most basic embedded systems are only capable of performing a single function to achieve a single goal. The functionality of embedded systems in more complicated systems is determined by an application program that allows the embedded system to be utilized for a given purpose in a specific application. Because of the capacity to have programs, the same embedded system can be utilized for a variety of tasks.



Fig.2.1 Simple Embedded system

### 2.1 ARCHITECTURE

This is a smart automatic security system having long range and giving accurate results. It not only helps to detect the obstacle, but it also keeps on reporting all the activities happening near the area. A special type of sensor is IR (Infrared) used to detect the amount of heat radiation (infrared radiation) that changes over time and space due to movement of people. If anyone tries to cross the border, then the IR sensor detects the obstacle, and it sends a signal to the microcontroller. The purpose of alarm system is to warn the obstacle at known distance as it is not always the terrorist who crosses the boundary there could be any villager or other person which may come under detection and hence to stop them from further movements, we alarm them by giving warnings and at the same time this also allows the security personals to get a brief idea about the current position as well as the motion of the obstacle.

### 2.2 BLOCK DIAGRAM

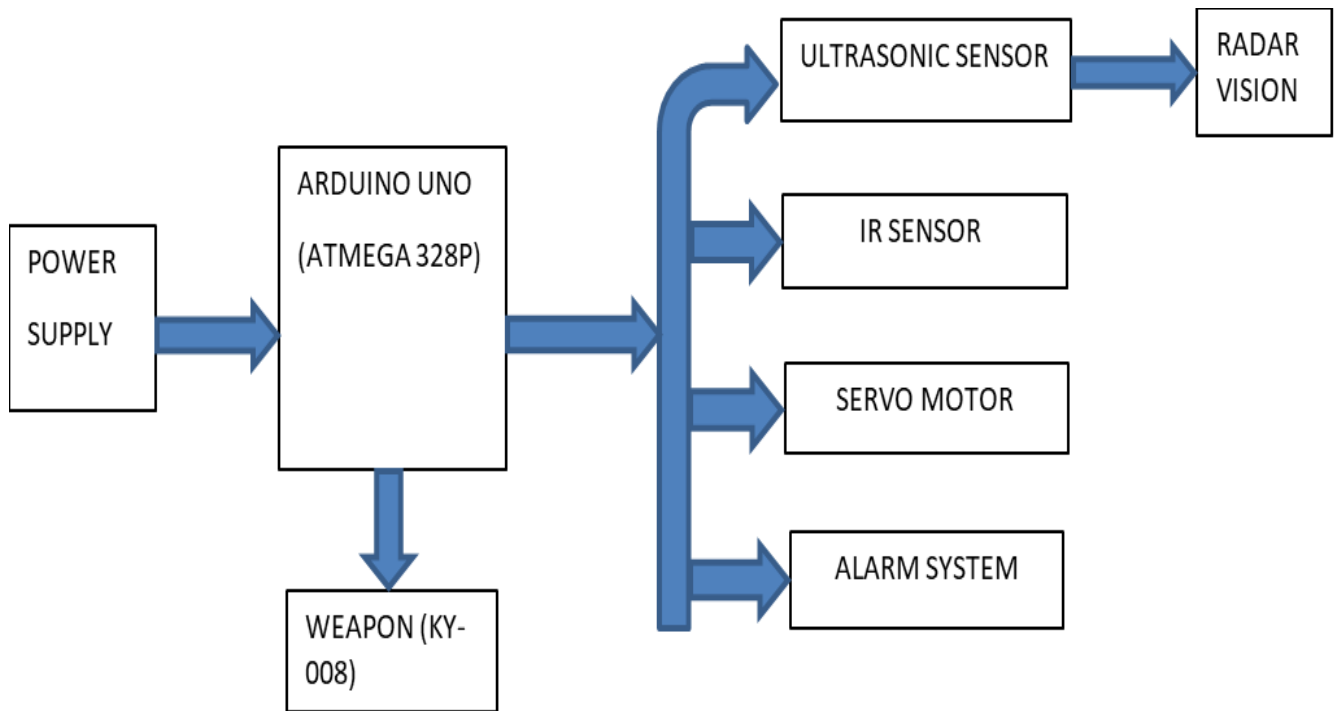

Fig 2.2: Block Diagram of the proposed system

The above fig. shows the Block Diagram of the proposed system. Here we have used Arduino Uno ATMEGA 328 microcontroller which is open source to implement an embedded-based system. ATMEGA 328 microcontroller sends 10-microsecond pulse width to the ultrasonic transmitter and thus echo back signal receives by TX module of ultrasonic. After this is done received pulse width is calculated by the microcontroller. Here we have used a servo motor on which an ultrasonic module is mounted to receive 180 degrees signal.

### 2.3 ARDUINO UNO

Arduino is a tool for making computers that can sense and control more of the physical world than your desktop computer.

Arduino can be used to develop interactive objects, taking inputs from a variety of switches or sensors, and controlling a variety of lights, motors, and other physical outputs. Arduino projects can be stand-alone, or they can communicate with software running on your computer (e.g., Flash, Processing, Max MSP.) The boards can be assembled by hand or purchased preassembled; the open-source IDE can be downloaded for free. The Arduino Uno is a microcontroller board based on the ATmega328 (datasheet). It has 14 digital input/output pins (of which 6 can be used as PWM outputs), 6 analog inputs, a 16 MHz ceramic resonator, a USB connection, a power jack, an ICSP header, and a reset button. The Uno differs from all preceding boards in that it does not use the FTDI USB-to-serial driver chip. Instead, it features the Atmega16U2 (Atmega8U2 up to version R2) programmed as a USB-to-serial converter.

### 2.4 ULTRASONIC SENSOR

An ultrasonic sensor is an instrument that measures the distance to an object using ultrasonic sound waves. An ultrasonic sensor uses a transducer to send and receive ultrasonic pulses that relay back information about an object's proximity. High-frequency sound waves reflect from boundaries to produce distinct echo patterns. Ultrasonic sensors work by sending out a sound wave at a frequency above the range of human hearing. The transducer of the sensor acts as a microphone to receive and send the ultrasonic sound. An ultrasonic sensor, like many others, uses a single transducer to send a pulse and receive the echo. The sensor determines the distance to a target by measuring time lapses between the sending and receiving of the ultrasonic pulse. The working principle of this module is simple. It

sends an ultrasonic pulse out at 40kHz which travels through the air and if there is an obstacle or object, it will bounce back to the sensor.



Fig 2.3: Ultrasonic sensor

## 2.5 IR SENSOR

IR sensor is an electronic device, that emits light to sense some object in the surroundings. An IR sensor can measure the heat of an object as well as detects motion. Usually, in the infrared spectrum, all the objects radiate some form of thermal radiation. These types of radiations are invisible to our eyes, but infrared sensors can detect these radiations. The emitter is simply an IR LED (Light Emitting Diode) and the detector is simply an IR photodiode. The photodiode is sensitive to IR light of the same wavelength which is emitted by the IR LED. When IR light falls on the photodiode, the resistances, and the output voltages will change in proportion to the magnitude of the IR light received.

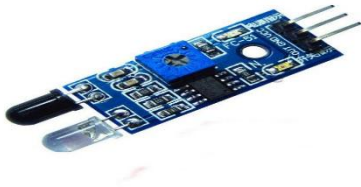

Fig 2.4: IR sensor

## 2.6 SERVO MOTOR

A servomotor (or servo motor) is a simple electric motor, controlled with the help of servomechanism. If the motor as a controlled device, associated with servomechanism is a DC motor, then it is commonly known as a DC Servo Motor. If AC operates the controlled motor, it is known as an AC Servo Motor. A servomotor is a linear actuator or rotary actuator that allows for precise control of linear or angular position, acceleration, and velocity. It consists of a motor coupled to a sensor for position feedback.



Fig 2.5: Servo motor

---

### 3. METHODOLOGY

The objective of the system is to build an implanted intruder identification framework in the border by utilizing an IR sensor and an Ultrasonic sensor using IoT. Numerous IR sensors are being used today however the sensor that is utilized will identify the Infrared beams that are transmitted from the human body. It can provide round-the-clock video surveillance at places where human deployment is not possible due to geographical, climatic, or other reasons. Multiple pyroelectric infrared sensors (PIR) are disguisedly installed on the border fencing which monitors the border area for any intrusion. To testify to the working of this system, after its designing, construction, and programming we placed a few objects in front of the ultrasonic sensor. As the servo motor started to rotate, our monitor started to display the output through processing IDE. Hence, when the sensor crossed over the object it showed a red segment with the distance and angle where the object is placed. The first object was placed at a distance of 29.5cm measured through a ruler and the system measured the distance at 31cm. While the second object was placed at a distance of 15 cm and the system measured it as 16cm. Hence the calculated efficiency turned out to be 95%.

---

### 4. CONCLUSION

Since this project does automatic intrusion sensing and detecting with the help of two sensors installed in the system. Real heroes of any country are their Soldiers. The project also aims at providing peace at the borders and reducing the tensions between the two countries. The Proposed system prevents the entry of intruders or antisocial persons, who are trying to cross the border without prior permission from the military with some bad intentions. Hence this system will reduce the cause of rioting as well as helps to prevent terrorist activities. So, the given proposed system also provides a safe and calm environment for the residents living near to military base and helps to create mutual harmony between military officers and civilians. The system can detect the intruder crossing the border areas, thereby helping the border security forces to monitor hostile zones of border areas efficiently with less manpower.

---

### REFERENCES

- i. Arjun, D., Indukala, P. K. & Menon, K. A. U. "Border surveillance and intruder detection using wireless sensor networks: A brief survey," International Conference on Communication and Signal Processing (ICCSP), pp. 1125- 1130, Chennai, 2017.
- ii. Jisha, R. C., Ramesh, Maneesha V. & Lekshmi, G. S. "Intruder tracking using wireless sensor network," In Computational Intelligence and Computing Research (ICCIC), 2010 IEEE International Conference on, pp. 1-5. IEEE, 2010.
- iii. Ajay B Devkatee, Nitesh H Chavan. & Manojkumar K Jha. "Defense Security System Border Security", IEEE Journal, 2016.
- iv. Singh, Dushyant & Kushwaha, Dharmender. "Automatic Intruder Combat System: A way to Smart Border Surveillance", Defense Science Journal, 67(1), pp. 50, 2016
- v. Bhaskar, Harish. "Integrated human target detection, identification and tracking for surveillance applications," 6<sup>th</sup> IEEE International Conference Systems, pp. 467-475, Sofia, 2012.