



## Smart Energy Meter for Smart Village

*Dayananda.T.B.<sup>1</sup>, Nisarga AM<sup>2</sup>, T Prajwal<sup>3</sup>, Vinay AS<sup>4</sup>, Kiran MR<sup>5</sup>*

<sup>1</sup>Associate Professor, Electrical & Electronics Engineering Dept Dr Ambedkar Institute of Technology  
(Autonomous, VTU affiliated, AICTE Approved)  
Bengaluru, India  
dayananda.tb@dr-ait.org

<sup>2,3,4,5</sup>Students, Electrical and Electronics Engineering Dept Dr Ambedkar Institute of Technology  
(Autonomous, under VTU, affiliated with AICTE)  
Bengaluru, India [nisargaam3@gmail.com](mailto:nisargaam3@gmail.com)<sup>2</sup>, [prajwalt1416@gmail.com](mailto:prajwalt1416@gmail.com)<sup>3</sup>,  
[vinayas1999@gmail.com](mailto:vinayas1999@gmail.com)<sup>4</sup>, [kiran30.mr@gmail.com](mailto:kiran30.mr@gmail.com)<sup>5</sup>.

### Abstract

This paper proposed and demonstrated Smart Energy Meter that the users will be able to monitor their current power consumptions (bill) anytime from anywhere by using their mobile phone via Short Message Services (SMS). It would be a huge beneficial for the customers if they can monitor their energy meter's power consumptions (bill) on a real-time basis. Arduino UNO, main controller, was the interface between energy meter and Global System for Mobile communication (GSM) module. GSM module connect the energy meter to users' mobile phone. Real Time Clock (RTC) DS1307 was used to get the real time to count and store the usage into the EEPROM. The program developed in C language with the Arduino syntax in the Arduino IDE. The proposed system demonstrated its capability to check the current usage (bill), notify when reaching the limit, reset the usage (bill) successfully, only via accessing GSM-based mobile phone.

Keywords: Energy Meter, Global System for Mobile Communication (GSM), Arduino, Short Message Services (SMS), and Real Time.

## 1 INTRODUCTION

Smart electrical energy meter technologies have been investigated and developed for approximately 10 years. Various technologies have been developed and used to measure the electrical consumptions. For the billing, the users will get the bill from the energy board after they generated and provided using the several methods. At the moment, most of the residences in Malaysia for example use the traditional electro - mechanical watt meters and the readings are not automated. The users will have to wait the bill of energy consumptions for every month to pay their energy bill. Normally, at the end of the month, a staff from the meter board billing will visit every house to read the meter reading and at the same time, give the bill to the users. An electricity meter or energy meter is a device that measures the amount of electric energy consumed to residence or business. There are two types of Domestic Ordinary Power Consumers meters single phase and three phases. The energy consumption is measured by all electrical services using kilowatt- hours meter with refer to kilowatt-hours (kWh) [1].

Then electronic meters was introduced with similar function with the electro-mechanical, but it replaces from analog to digital system. With this system users can note down the voltage, power reading unit, current and the time, date of the energy consumption. This system just gives some advantages over the previous meter reading. After the electronic ones, the meter reading developed with the Bluetooth based technology which is the wireless communication and also known as Automatic Meter Reading (AMR). This system is wireless and the personal computer could be used to record the power consumption of energy meter. The reading meter will be saved to the database and bill will be generated. The latest technology is using a Global System for Mobile Communication (GSM) based system. This system replace the Bluetooth technology and the data sent using Short Message Service (SMS) to the customer and the energy board [1].

In Malaysia, the energy provider is Tenaga Nasional Berhad (TNB). Mostly, TNB uses electronic meter as meter energy. Electronic meters are identifiable through the LCD display panels. Whilst electromechanical meters are still in use, TNB is gradually phasing them out through replacement programs. All TNB energy meters installed at the premises have been calibrated and tested in accordance with Malaysian Standards ISO/IEC 17025: 2005.

## 2 OVERVIEW OF THE SYSTEM

The System consists of hardware and software part. Figure 1, the hardware parts, shows the block diagram of energy meter project that the users can monitor their home current power consumptions anytime and anywhere. As for the software part, all the program located in Arduino UNO, using C language. Arduino UNO, as the main controller, connect energy meter, GSM module, and other sensors/peripherals so they can communicate each other. And Arduino UNO can only work after we uploaded the designed program into it.

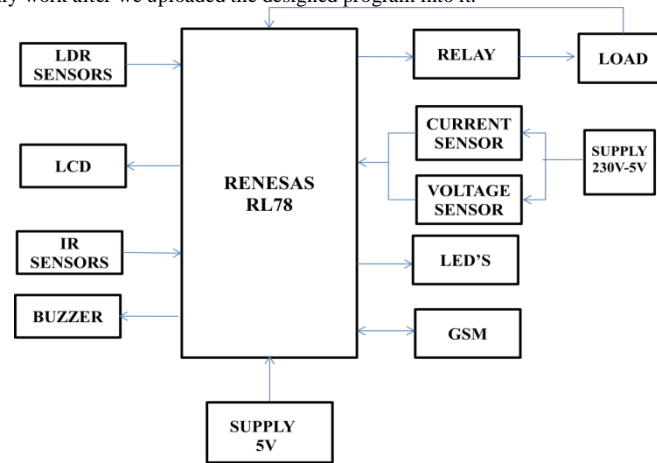

**Figure 1:** Block Diagram of the System

## 3 Hardware System

According to [2], Automatic Meter Reading system (AMR) continuously monitors the energy meter and sends data on request of the service provider through SMS. It saves huge human labor. The data received from an energy meter has been stored in database server, which was located at the electricity Board station through an SMS gateway for further processing by the energy provider. Automatic meter reading system helps the customer and energy service provider to access the accurate and updated data from the energy meter. AMR System can send energy consumption in hourly, monthly or on request. This data is sent to a central system for billing and troubleshooting. These data are stored into the database server for processing and recording. This technology mitigates labor cost, collection time, energy theft, avoids late payment. Adding to this it increases data security, improved customer service, reduced revenue losses. This system provides freedom for electricity companies to take action against lenient customers who have outstanding dues, otherwise companies can disconnect the power of customer [3]. The energy meter that chosen and suitable for this project is single phase meter from Smart Meter Technology Sdn. Bhd because it has a clear blinking LED indicator for 1Wh pulse and also have direct pulse output connection that compatible to the Arduino. To make sure the pulse taken accurately, the output pulse from LED blinking is more suitable. This meter use 240V AC current and count 1Wh per pulse. As prototype to count the pulse, the 2 units of lamps 100W and 25W was connected to this meter as shown in Figure 2.



**Figure 2:** Energy meter with loads of 2 lamps

In figure 2 shows the box covered the circuit, only Energy meter and LCD can be seen from the outside. The material for the box is plastic PVC with A4 size and cover with stickers wallpaper. The socket was implementing as a switch between load and the energy meter. So that, 2 lamp can be used as the load. Each lamp can give load for 100W for 1 hours. The LCD display had been place at the top side of the meter while beside the LCD, the LED indicator will blink when counting 1 pulse. The sensor was placed close to the LED at the Energy Meter to catch the blinking when 1 pulse. This

prototype might be different to the real product in the future. It must be well arranged without the socket close to the Energy meter and the box should be built with the proper material such as wood or perspex transparent.

As for GSM, It is the second generation digital cellular system. Digital transmission was used rather than analog transmission in order to improve transmission quality, system capacity, and coverage area. GSM works on three frequencies 900 MHz, 1800 MHz and 1900 MHz. To make efficient use of frequency bands GSM networks uses combination of FDMA (frequency division multiple access) and TDMA (time division multiple access) [4]. GSM operators have set up roaming agreement with foreign operator which help users to travel abroad and use their cell phones. GSM module was used for receiving SMS from users mobile phone that automatically enable the controller to take further action like switching ON and OFF electrical applications such as fan, air - conditioner, light and other [5]. The system was integrated with microcontroller and GSM network interface using arduino or other microcontroller and software was utilized to accomplish the integration. In this project, GSM module SIM900 is chosen to use. The SIM900 is a complete Quadband GSM/GPRS solution in a SMT module which can be embedded in the customer applications. Featuring an industrystandard interface, the SIM900 delivers GSM/GPRS 850/900/1800/1900MHz performance for voice, SMS, Data, and Fax in a small form factor and with low power consumption. [6] define that, GSM module which contain of SIM card and subscription with mobile operator will operate like a mobile phone. The GSM module must be connected to Arduino with TX and RX to pin 2 and 3 respectively. When switch 'ON' the module, the blue LED will be 'ON' and after push the Button Key the red LED will be blinking. That shows the GSM in good condition, but we cannot define the line connected or not until we program the Arduino to test the GSM module.

There are other technologies beside GSM that can act as interface between the energy meters to the users, so that the users can monitor the current usage of their power consumptions. Technologies like Bluetooth and ZigBee are the some of the them. ZigBee is a radio frequency (RF) communications standard based on IEEE 802.15.4. ZigBee is a new wireless communication technology, representing a wireless sensor network which is highly reliable, secure, low data rate, low power consumption, low cost and fast reaction. The Zigbee coordinator is responsible for creating and maintaining the network. All communication between devices propagates through the coordinator to the destination device. The wireless nature of ZigBee helps overcome the intrusive installation problem with the existing systems identified earlier. The ZigBee standard theoretically provides 250kbps data rate, and as 40kbps can meet the requirements of most control systems, it is sufficient for controlling the system. The low installation and running cost offered by ZigBee helps tackle the expensive and complex architecture problems with existing systems, as identified earlier [7]. According to [8], Zigbee enables broad-based deployment of wireless networks with low-cost, low-power solutions. It provides the ability to run for years on inexpensive batteries for a host of monitoring and control applications. Smart energy/smart grid, AMR (Automatic Meter Reading), lighting controls, building automation systems, tank monitoring, HVAC control, medical devices and fleet applications are just some of the many spaces where zigbee technology is making significant advancements. But the limitation of ZigBee against GSM is the coverage or distance area. Unlike ZigBee that has distance limitation up to hundred metres, we can find or get GSM signal in almost everywhere. This is the main consideration why we use GSM instead of ZigBee technology. So that the users can monitor their home power consumption from anywhere as long as they have cellular (GSM) signal in their mobile phones. Different frequencies have different characteristics, low frequency tend to have better penetration of particular materials compare to high ones, with the assumption of using same power. Experiment conducted in [9] showed the microwave capability of penetrating material of water to measure moisture content.

A microcontroller is an integrated circuit that contains processor core, memory and programmable input and output peripherals. It also known as small computer that designed for embedded applications. On the other hand, the microcontroller incorporates all the features that founds in microprocessor. However, it has also added features to make a complete microcomputer system on its own. The microcontroller has built-in ROM, RAM parallel I/O, serial I/O, counters and clock circuit [10]. The project use Arduino UNO for the microcontroller, The host processor for the arduino UNO is the Atmel Atmega328. The '328' is the 28 bit microcontroller. The architecture is based on Reduced Instruction Set Computer concept which allows the processor to complete 20 million instructions per seconds operating at 20MHz. The ATmega328 is equipped with three main memory section which is flash programmable read only memory (EEPROM), Static random access memory (SRAM) and byte-addressable EEPROM for data storage [11]. The Arduino Uno is the

'standard' Arduino board and the most readily available. It is have 32KB of flash memory, 2KB of SRAM and 1KB of EEPROM memory. With a total of 14 digital I/O pins and 6 analog I/O pins, this is a very capable device, able to run most programs.

The DS1307 serial real-time-clock (RTC) is low power, full binary-coded decimal (BCD) clock / calendar plus 56 bytes. It communicates to Arduino over I<sup>2</sup>C connection. A real time clock just act like watch, it use 3V battery and keep time even when no current [12]. Real time clock was used in this project to get the real time counting and storing the bill in the EEPROM. With the real time clock, the bill can be reset at 1<sup>st</sup> date for every month. It used battery 3V to maintain their life even no current flow.

For light to voltage converter, the TSL257 is combination of photodiode a transimpedance amplifier on a single monolithic CMOS intergrated circuit, it is high-sensitivity low-noise light to voltage optical converter. Output voltage is directly proportional to light intensity (irradiance) on the photodiode [13]. The TSL 257 light to Voltage converter also known as sensor because it detect the light and convert it to the voltage. It is used as interface energy meter to the arduino. It connected to the digital pin at the arduino and declares as digital write output 'HIGH'. When the LED at energy meter blinking, this sensor will sent the voltage to the arduino as a pulse 1. The system also added liquid crystal display (LCD), the display unit that used in this project is a 16 X 2 alphanumeric LCD which consist of 16 character and 2 line. It can act as the output display to show the bill, unit and GSM status on the meter.

#### 4 Software System

Figure 3 shows the flowchart of the program used in the project, developed in C language with the Arduino syntax in the Arduino IDE. The software is also used for loading the program code into Arduino board. In this project, the arduino IDE was used to program, create, debug and upload the coding into the microcontroller. There are parts that need to be program which are digital write input/output, GSM network, Real time clock and EEPROM.

Each program need to include the libraries of the coding such as for GSM use GSM.h or SIM900.h and other type of libraries but it depend on the coding requirement. For this project, it used libraries GSM.h, DS1307RTC.h, Wire.h, LiquidCrystal.h, and EEPROM.h

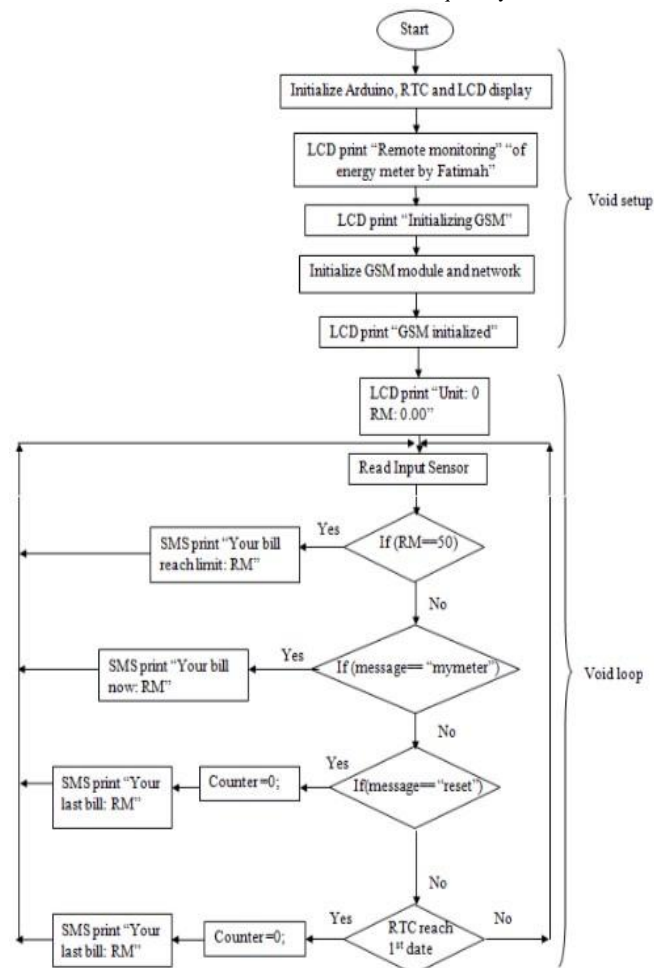

Figure 3: Flowchart of the Program

## 5 Result and Discussion

There are two parts that was combined to make the system. The two parts that was combined were circuit for interfacing energy meter to arduino and interface from GSM module to Arduino. Circuit operation was in good condition with the right sequence of program that uploaded into microcontroller. For the light to voltage sensor part, Arduino with microcontroller ATmega238 was used to count the input, calculate the bill and store it into EEPROM. Real Time Clock was used to set the reset counter every month. LED indicator was blinking when input from sensor detected. The value of unit and bill price was display at the LCD display as set in the microcontroller. At the program, the number of mobile phone user was set to receive a message when limit reach. In GSM network, the network plan SIM card was used to transmit message to mobile phone. To combine this two part system, the GSM module Tx and Rx was connected to pin 2 and 3 respectively to Arduino while RTC used analog pin A4 and A5 at Arduino for CLOCK and RS. The other components such as LCD, LED and light to voltage sensor were connected to digital port 4 to 13.

If the users want to check their current bill, they just type command 'mymeter' and send it to energy meter, and the energy meter will send the current bill as shown in Figure 6.

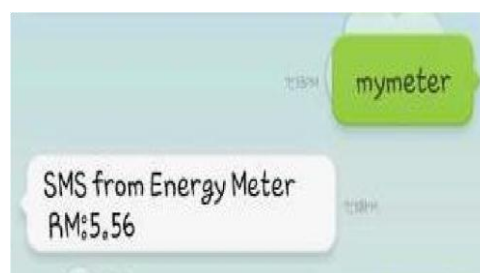
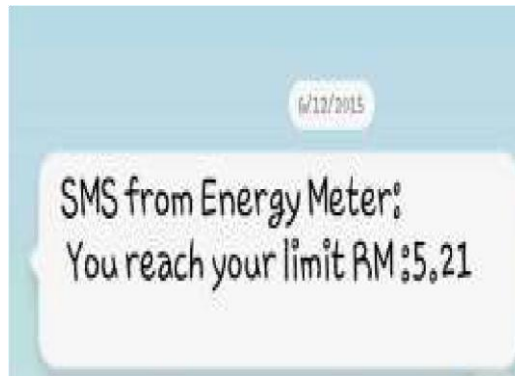

Figure 6: Check the users' current bill

And if the bill has reached the limit set before, energy meter will send SMS as well automatically as shown in Figure 7.



**Figure 7:** Notification when reach a limit

There are two ways to connect the energy meter to an Arduino UNO, either by using TSL257 sensor or wire connection at the output pulse of the energy meter. By using the direct connection from energy meter to Arduino, the unstable system had been occurring. The reading of energy meter still counting even the lamp supply in OFF condition. The meter LED indicator was not blinking when the power supply is OFF, but the LCD display remain showing the energy meter counting the pulse. This phenomenon happened when the meter will take every current and voltage flow at their circuit even the voltage and current from the Arduino UNO and GSM module. That means, the system is totally wrong because the counting pulse is not 100% from the Lamp that connected to the energy meter, it came from the other source. TSL257 sensor the light to voltage sensor, it is the component that can convert light to voltage. This component tested to make sure the input given to Arduino was correct sources. When installing TSL 257 to the energy meter, the sensor must be covered properly with the black tape to avoid the light sources from the surrounding. This component has a high sensitivity that will detect any light and convert it to voltage. The result showed the best way to monitor the energy meter is by using this sensor or converter. The figure 8 showed the test circuit diagram.

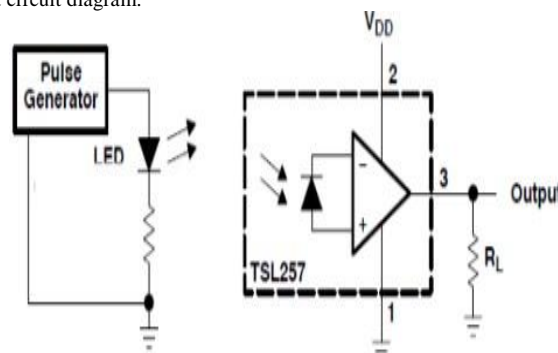

**Figure 8:** The Test Circuit Diagram

Before the system work successfully, some problems occurred during setup and test the system. The LCD was not work properly, there were weird characters showed up at the display. This was caused by the pulse input from the energy meter to Arduino cannot connect directly from the 'pulse output connection' at the meter. This issue was solved by using TSL257 light to voltage converter as the interface between the energy meter and Arduino, by using the digital write and digital read command. Another problem occurred was Arduino RAM was not enough when compiling the microSD card coding, and the solution for that issue, EEPROM had been used as the storage data to replace the microSD card. The RAM for Arduino UNO is 2Kb and the coding that enough for that space only combination of RTC, LCD, GSM and Sensor. The libraries for the microSD card more than 900 byte and there was another solution if the microSD card also needs to be used by finding the smaller microSD card libraries. Cellular technology like GSM is one of main part in the project. focus of this project is the GSM application. Compared to another telecommunication technologies such as Bluetooth, Zigbee, wifi and others, GSM network is more suitable because it's available almost everywhere. Meaning the users can access their energy meter from anywhere as long as they have the signal in their mobile phone.

The project is proposed for single phase residential only, it is not suitable for the 3 phase residential and buildings. It require stable current and it doesn't built in with the backup power supply if breakouts occur. Even the EEPROM saved the data, the system will reset the counter and at LCD display will shows "Unit: 0 RM: 0.00" when the power is ON back again after the breakout occurs. The data at EEPROM can only be store for 1Kb and will be replace the address when it is full. Another limitation is that the users cannot set the 'limit' of the bill for every month using SMS but they need to modify the coding by themselves or used the current limit that had been set in the coding. So, for future work or recommendation, adding the rechargeable battery to make sure the system can be operate and standby to counting even when breakout. The rechargeable battery that can be use is lead acid battery. It will backup if the system is shutdown. Another recommendation is using the Arduino Mega as the main controller, so that there are many things can be added because arduino UNO will not have enough RAM if we combine with many sensors or inteerfaces. When the RAM is not enough, it will occurs in unstable system.

---

## 6 Conclusion

Using this project we can reduce manual effort to take the readings from the energy meter which is a cost effective solution. It reduces manpower. It is user friendly and we can enhance this project, in which an electricity department can send the message to the consumer about electricity consumption. This can also include current and potential transformers which gives the power consumption in analog form. According to the tariff rates stored in the microcontroller the consumed units and costs are displayed on the LCD. It facilitates energy efficiency since information feedback is shown to the consumers to reduce usage.

Smart street lights contribute to more livable cities by helping to improve safety and reduce congestion. Reduced energy cost. Smart street lights more efficiently manage electricity, leading to greater cost savings compared to simple LED luminaires. Increased revenue opportunities

## ACKNOWLEDGEMENT

The authors would like to thank Universiti Teknikal Malaysia Melaka (UTeM) for sponsoring this work under the Grant PJP/2015/FTK(30A)/S01455.

---

## REFERENCE

- [1] Himanshu K Patel, TanishMody, AnshulGoyal, "Arduino Based Smart Energy Meter using GSM "2018 International conference on power and computingTechnologies.
- [2] Himshekar Das "GSM Enabled Smart Meter and Automation of Home appliances" 2016 IEEE conference on System, Process and control, pp 306-309.
- [3] AkshayHankare, AnishPai, "Intelligent street light system (Automated Street Lights Based on VehicleDetection)".
- [4] "Mustafa Saad, Ahamed Salah: Automatic Street Light Control System Using Microcontroller"2006 IEE conference pp 217-222.
- [5] "Automated Control Systems and Metering of Energy (Askme) in Industrial Enterprises", URL: [http://edulib.pgta.ru/els/as\\_ucheta\\_energositelevy.pdf](http://edulib.pgta.ru/els/as_ucheta_energositelevy.pdf). (Accessed 14 March2018).
- [6] Heap, Brian. "Smart villages: New thinking for off-grid communities worldwide." Essay Compilation, Banson(2015).
- [7] "This Is How India Created Its First 'Smart Village", World Economic Forum., 2017.  
Internet:<https://www.weforum.org/agenda/2016/10/india-creates-first-smartvillage/>
- [8] Han, Dae-Man, and Jae-Hyun Lim. "Smart home energy management system using IEEE 802.15. 4 and zigbee." IEEE Transactions on Consumer Electronics 56.3(2010).
- [9] Saumilmadgavkar, AkshayHankare, : "Inteligent Street light system Automated streetlight based on Vehicle Detection" fromSLIDESHARE.
- [10] From[www.google.com](http://www.google.com)